



Echotel® Models 960/961 Ultrasonic Level Switches for Hygienic Applications

DESCRIPTION

Echotel Model 960/961 Ultrasonic Level Switches use pulsed signal technology for superior performance in difficult process conditions, and to provide excellent immunity from sources of electrical noise interference. Extensive self-testing of the electronics and transducer make this advanced switch suitable for a wide variety of hygienic level switch applications.

Model 960 Switches use AS-Interface® (AS-i) bus digital communications for high or low single point liquid level measurement. The AS-i bus system provides a digital serial interface with a single unshielded two-wire cable for power and data transfer.

Model 961 is offered with either a 5 amp relay or a current shift electronics. The relay output electronics has a DPDT relay for level detection, and a SPDT malfunction relay. The current shift version indicates 8 mA during normal operation, 16 mA as a level alarm condition and a user selectable 3.6 or 22 mA malfunction indication.

The 960/961 switches are designed for the stringent requirements of hygienic applications. These switches are offered with a deep-drawn 304 stainless steel housing that is favorable to CIP and SIP procedures. A 20 R_a surface finish is featured with hygienic Model 960/961 transducers. These transducers are available with 1 1/2" & 2" Tri-Clamp® fittings, and DN65 Varivent® flanges.

FEATURES

- Self-test technology provides unsurpassed reliability and testing of electronics, transducer, piezoelectric crystals, and electromagnetic noise
- 20 R_a surface finish with Tri-Clamp and Varivent fittings
- Adjustable time delay for turbulent aerated liquids
- Tip-sensitive transducer measures level within 1/4" of the vessel bottom
- Pulsed signal technology provides superior performance in difficult process conditions



Model 960/961
(with Varivent® fitting)

Model 960/961
(with Tri-Clamp® fitting)

APPLICATIONS

- High or low level alarm
- CIP buffer tanks
- WFI systems
- Hygienic pump protection
- Beer vats
- Leak detection
- Liquid chromatography skids
- Overfill protection

INDUSTRIES

- Bio-technology
- Chemical
- Brewing and spirits
- Food and beverage
- Pharmaceutical

PULSED SIGNAL TECHNOLOGY



Model 960/961 switches use pulsed signal technology to detect the presence or absence of liquid in an ultrasonic transducer gap. The transducer uses a pair of piezoelectric crystals that vibrate at a given frequency when subjected to an applied voltage. The transmit crystal converts the applied voltage from the electronics into an ultrasonic signal. When liquid is present in the gap, the receive crystal senses the ultrasonic signal and converts it back into an electrical signal. This signal is sent to the electronics to indicate a wet gap condition. When no liquid is present, the ultrasonic signal is attenuated and is not detected by the receive crystal.

Challenging process conditions like aeration, suspended solids, and high viscosities are overcome by using pulsed signal circuitry in 960/961 switches. Unlike many tuning forks, pulsed signal ultrasonic switches do not need to be configured for different media densities, making these units the most universally applied level switches on the market today.

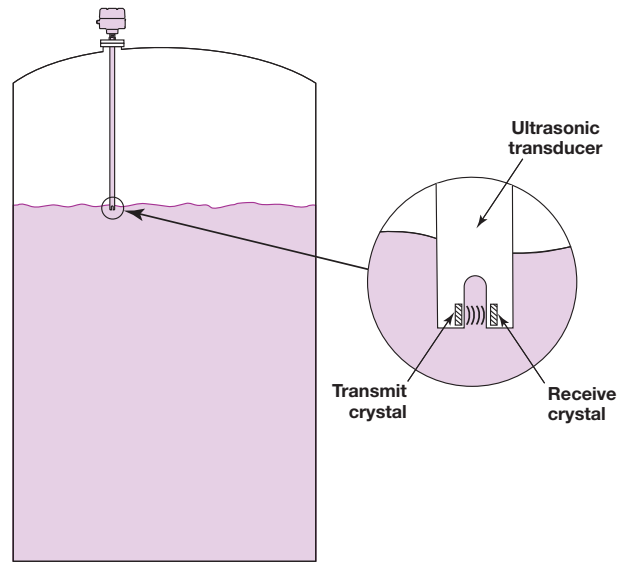

Ultrasonic signal transmission across transducer gap

ADVANCED SELF-TEST AND DIAGNOSTICS

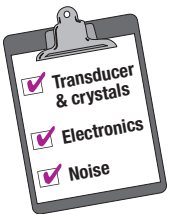

Ultrasonic switches are often used as the last means of detecting whether a process vessel will overflow and cause a spill of potentially hazardous liquids, or empty out and possibly cavitate the pumps. In these critical applications it is desirable to have a method of periodically testing the ultrasonic switch to ensure that it is functioning properly.

Model 960/961 switches feature an advanced self-test technology that not only tests the electronics, transducer, and piezoelectric crystals, but also tests for the presence of industrial sources of environmental noise. Should the switch detect any problems a malfunction output is generated to alarm the user, and a red LED is lit to indicate an alarm condition.

A microprocessor in the 960/961 electronics continuously monitors all self-test data. Should a fault occur, the microprocessor can determine whether the malfunction is due to the electronics, transducer, piezoelectric crystals, or the presence of environmental noise. A pushbutton and Fault LED is used to assist in troubleshooting the switch:

- ✱ One flash of the Fault LED indicates a problem with the transducer or piezoelectric crystals
- ✱✱ Two flashes of the Fault LED indicates a problem with one of the electronics boards
- ✱✱✱ Three flashes of the Fault LED indicates excessive levels of environmental noise

ADJUSTABLE TIME DELAY



Turbulence and splashing can cause some fixed time response switches to produce false level alarms. Model 960/961 switches overcome this difficulty with an adjustable time delay feature.

A potentiometer allows a ½ to 45 second delay to be set to disregard waves or splashes, and reliably detect the true liquid level.



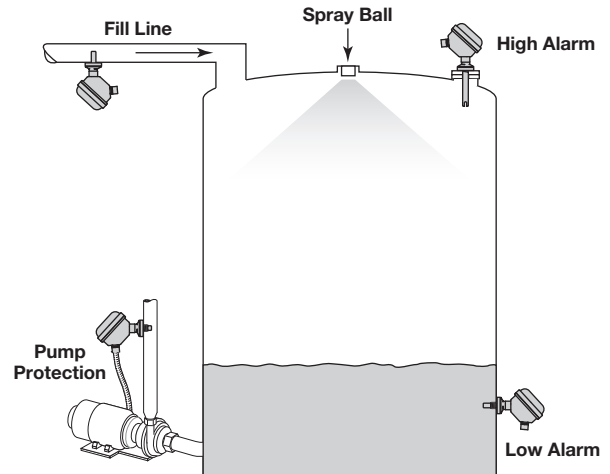

APPLICATIONS

Model 960/961 Switches may be used for high or low level alarm, empty pipe detection and pump protection in a wide variety of hygienic applications. Available with a 304 stainless steel electronics housing and a 20 R_a surface finish transducer, typical applications include:

- CIP/SIP day tank point level
- Water for Injection (WFI) storage
- Liquid chromatography skids
- Brewery fill lines
- Condensate receiver tanks



AGENCY APPROVALS

AGENCY	APPROVED MODELS	PROTECTION METHOD	AREA CLASSIFICATION
FM & CSA  	960-58AX-030 960-58AX-031 961-50AX-010 961-50AX-011 961-XDAX-030 or 961-XDAX-031 with transducers: 9X1-XXXX-XXX	Explosion Proof	Class I, Div. 1, Groups B, C, & D Class II, Div. 1, Groups E, F, & G Class III, Type 4X, IP 66, T6
	960-58AX-074 960-58AX-075 961-XXAX-01X 961-XXAX-03X or 961-XXAX-07X with transducers: 9X1-XXXX-XXX	Non-Incendive	Class I, Div. 2, Groups A, B, C, & D Class II, Div. 2, Groups F & G Class III, Type 4X, IP 66, T4 IP67 for 304 Stainless Steel Housing
	961-50AX-01X with transducers: 9X1-XXXX-XXX	Intrinsically Safe	Class I, Div. 1, Groups A, B, C, & D Class II, Div. 1, Groups E, F, & G Class III, Type 4X, IP 66, T4
ATEX 	960-58AX-0C0 960-58AX-0C1 961-XXAX-0C0 961-XXAX-0C1 with all metallic transducers*	Explosion Proof	Ex II 1/2 G, EEx d IIC T6
	961-50AX-0AX with all metallic transducers*	Intrinsically Safe	 Ex II 1 G, EEx ia IIC T5
AS-i 	These units have been tested to AS-Interface Specification EN50295 and IEC 62026-2 , and have met the demands of the AS-Interface Test Requirements. AS-Interface certificate #76401		

*Consult factory for model numbers

 These units have been tested to EN 61326 and are in compliance with the EMC Directive 89/336/EEC.

ELECTRONICS SPECIFICATIONS

MODEL 960 WITH AS-Interface

Supply Voltage	21 to 31 VDC
AS-i Version	V 3.0
AS-i Slave Type	A/B (Maximum of 62 nodes)
AS-i Slave Profile	S-0.A.E
AS-i Data Bits	Gap Condition: D2 = 1 with a wet gap D2 = 0 with a dry gap
	Malfunction Status: D3 = 1 during malfunction D3 = 0 in normal state
Connectable Load	EN50295 and IEC 62026-2
Power Consumption	Less than 1 watt
Ambient Temperature	Electronics: -13° to +160° F (-25° to +70° C)
Storage Temperature	Electronics: -40° to +160° F (-40° to +70° C)

MODEL 961 WITH RELAY OUTPUT

Supply Voltage	18 to 32 VDC, or 102 to 265 VAC, 50/60 Hz
Relay Outputs	One DPDT level relay and one SPDT malfunction relay
Relay Ratings	DPDT: 5 amps @ 120 VAC, 250 VAC, and 30 VDC, 0.4 amp @ 110 VDC SPDT: 5 amps @ 120 VAC, 250 VAC, and 30 VDC, 0.15 amp @ 125 VDC
Fail-safe	Selectable for high or low level
Power Consumption	Less than 3 watts
Ambient Temperature	-40° to +160° F (-40° to +70° C)

MODEL 961 WITH CURRENT SHIFT OUTPUT

Supply Voltage	11 to 35 VDC
Current Shift Output	8 mA normal operation, 16 mA level alarm (± 1 mA) 3.6 mA or 22 mA selectable fault signal (± 1 mA)
Loop Resistance	104 ohms with 11 VDC input, 1100 ohms with 35 VDC input
Fail-safe	Selectable for high or low level
Power Consumption	Less than 1 watt
Ambient Temperature	-40° to +160° F (-40° to +70° C)

TRANSDUCER SPECIFICATIONS

Operating Temperature	-40° to +325° F (-40° to +163° C)
Maximum Pressure	1" and 2": 2000 psi (138 bar) 3" to 130": 1500 psi (103 bar)
Operating Frequency	2 MHz
Surface Finish	20 R _a (when ordered with 4th digit code S)

PERFORMANCE SPECIFICATIONS

Repeatability	±0.078" (± 2 mm)	
Response Time	½ second typical	
Time Delay	Variable 0.5 – 45 seconds on rising and falling levels	
Self-Test	Automatic:	Continuously verifies operation of electronics, transducer, piezoelectric crystals, and electrical noise
	Manual:	Push button verifies operation of electronics, transducer, and piezoelectric crystals
Shock Class	ANSI/ISA-S71.03 Class SA1	
Vibration Class	ANSI/ISA-S71.03 Class VC2	
Humidity	0-99%, non-condensing	
Electromagnetic Compatibility	Meets CE requirements EN 61326	

PHYSICAL SPECIFICATIONS

Housing Material	Cast aluminum A356-T6, or deep drawn 304 stainless steel	
Cable Entry	Cast Aluminum:	Dual ¼" NPT, or M20
	304 Stainless Steel:	Dual ½" NPT, or M20

DIMENSIONAL SPECIFICATIONS

INCHES (m m)

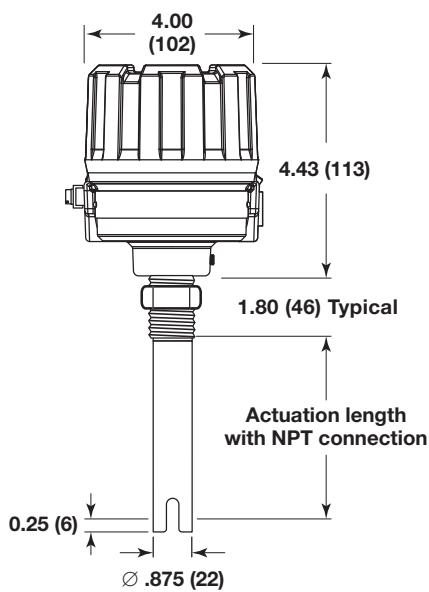

**Model 960/961
with NPT Connection**

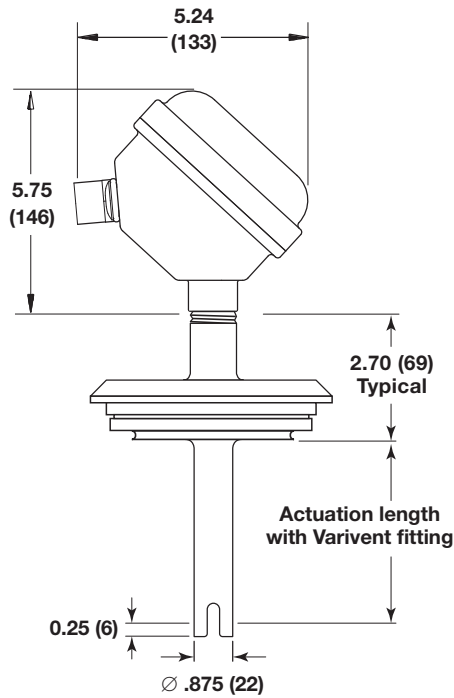

**Model 960/961
with DN65 Varivent® Flange**

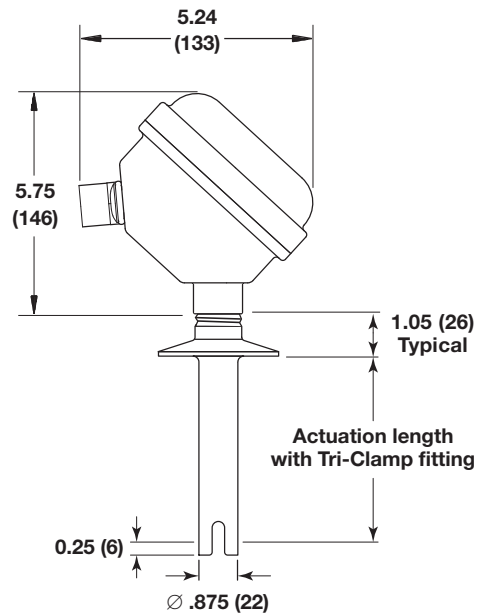

**Model 960/961
with Tri-Clamp® fitting**

MODEL NUMBER

960/961 ELECTRONICS

Models available for quick shipment, usually within one week after factory receipt of a purchase order, through the Expedite Ship Plan (ESP)

BASIC MODEL NUMBER

960	Actuator-Sensor-Interface (AS-i) electronics
961	Relay or current shift electronics

INPUT POWER

2	24 VDC line-powered (Model 961 only)
5	24 VDC loop-powered (Model 960 & 961)
7	102 to 265 VAC line-powered (Model 961 only)

OUTPUT SIGNAL

0	mA current shift for Model 961 (available with Input Power code 5)
8	Actuator-Sensor-Interface (AS-i) for Model 960 (available with Input Power code 5)
D	5 amp gold flash relays for Model 961 (available with Input Power codes 2 or 7)

COVER

0	Standard cover
1	Glass window cover

MOUNTING

0	Integral
---	----------

AGENCY APPROVAL

1	FM/CSA Intrinsically safe, Non-incendive & Explosion proof * (available with Output Signal code 0, and Housing codes 0, 1, 4 & 5)
3	FM/CSA Explosion proof & Non-incendive (available with Output Signal codes 8 & D, and Housing codes 0 & 1)
7	FM/CSA Non-incendive (available with Output Signal codes 0, 8 & D, and Housing codes 4 & 5)
A	ATEX II 1G EEx ia II C T5, Intrinsically safe (available with Output Signal code 0, and Housing codes 0, 1, 4, & 5)
C	ATEX II 1/2 G EEx d II C T6, Explosion proof (available with Output Signal codes 0, 8 & D, and Housing codes 0 & 1)

*Explosion Proof approvals not available with housing codes 4 & 5

HOUSING & CONDUIT CONNECTION

0	Cast aluminum with 3/8" NPT dual conduit entries
1	Cast aluminum with M20 dual conduit entries
4	Deep drawn 304 stainless steel w/ 1/2" NPT dual conduit entries
5	Deep drawn 304 stainless steel w/M20 dual conduit entries

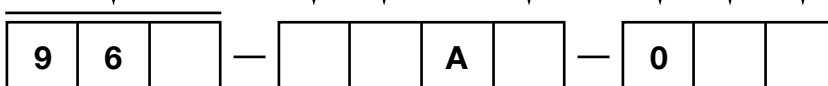

MODEL NUMBER

9 6 0 / 9 6 1 SINGLE POINT TRANSDUCER

Models available for quick shipment, usually within one week after factory receipt of a purchase order, through the Expedite Ship Plan (ESP)

TRANSDUCER UNIT OF LENGTH

A	English (length in inches)
M	Metric (length in centimeters)

MATERIALS OF CONSTRUCTION

A	316/316L stainless steel
S	316/316L with 20 Ra hygienic finish (use only with Process Connection codes 3T, 4T, or VV)

PROCESS CONNECTIONS

11	3/4" NPT
3T	1"/1 1/2" Tri-Clamp® fitting
4T	2" Tri-Clamp® fitting
VV	DN65 – Varivent®

ACTUATION LENGTH (unit of length specified in second digit)

1" to 130" in 1" increments 1" minimum for NPT process connections 2" minimum for 3T, 4T & VV process connections Example: 4 inches = 004
Available English ESP lengths: 1", 2", 4", 6", 8", 12"
3 cm to 330 cm in 1 cm increments 3 cm minimum for NPT process connections 5 cm minimum for 3T, 4T & VV process connections Example: 6 centimeters = 006
Available metric ESP lengths: 3, 5, 10, 30 cm

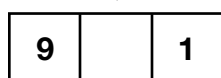

QUALITY



The quality assurance system in place at Magnetrol guarantees the highest level of quality throughout the company. Magnetrol is committed to providing full customer satisfaction both in quality products and quality service.

Magnetrol's quality assurance system is registered to ISO 9001 affirming its commitment to known international quality standards providing the strongest assurance of product and service quality available.

ESP

Expedite Ship Plan

Several Echotel Model 961 units are available for quick shipment, usually within one week after factory receipt of a purchase order, through the Expedite Ship Plan (ESP).

To take advantage of ESP, simply match the color coded model number codes (standard dimensions apply).

ESP service may not apply to orders of ten units or more. Contact your local representative for lead times on larger volume orders, as well as other products and options.

WARRANTY



All Magnetrol electronic level and flow controls are warranted free of defects in materials or workmanship for one full year from the date of original factory shipment.

If returned within the warranty period; and, upon factory inspection of the control, the cause of the claim is determined to be covered under the warranty; then, Magnetrol will repair or replace the control at no

cost to the purchaser (or owner) other than transportation.

Magnetrol shall not be liable for misapplication, labor claims, direct or consequential damage or expense arising from the installation or use of equipment. There are no other warranties expressed or implied, except special written warranties covering some Magnetrol products.

For additional information, see Instruction Manuals 51-632 & 51-646.



5300 Belmont Road • Downers Grove, Illinois 60515-4499 • 630-969-4000 • Fax 630-969-9489 • www.magnetrol.com
145 Jardin Drive, Units 1 & 2 • Concord, Ontario Canada L4K 1X7 • 905-738-9600 • Fax 905-738-1306
Heikensstraat 6 • B 9240 Zele, Belgium • 052 45.11.11 • Fax 052 45.09.93
Regent Business Ctr., Jubilee Rd. • Burgess Hill, Sussex RH15 9TL U.K. • 01444-871313 • Fax 01444-871317

Copyright © 2009 Magnetrol International, Incorporated. All rights reserved. Printed in the USA.
Performance specifications are effective with date of issue and are subject to change without notice.

AS-Interface® is a registered trademark of the AS-International Association
Kynar® is a registered trademark of Elf Atochem North America, Inc.
Hastelloy® is a registered trademark of HAYNES INTERNATIONAL, INC. (DELAWARE CORPORATION)
Monel® is a registered trademark of the INCO family of companies
Tri-Clamp® is a registered trademark of Ladish Co.
Varivent® is a registered trademark of Tuchenhagen GmbH LTD

ProcessHQ, Inc.

21935 Plummer Street
Chatsworth, CA 91311
818 341-1782 (voice)
818 475-1589 (fax)
info@processHQ.com

BULLETIN: 51-160.1
EFFECTIVE: October 2009