

M600 Multi-Port Valves for Sterile Applications

Product overview and technical data





GEMÜ®

Innovative technology

GEMÜ is a leading world-wide manufacturer of high quality valves, measurement and control systems.

Fritz Müller established GEMÜ in 1964, and since then, the company developed internationally with a large number of production centres, subsidiaries and trading companies on every continent.

GEMÜ provides engineered control solutions for a large number of process and engineering plant, such as :

- Industrial plant and machine construction
- Automobile industry
- Water / waste water treatment
- Chemical industry
- Steel works
- Mining and metal extraction
- Power stations
- Shipbuilding industry
- Petrochemical industry
- Paper industry
- Pharmaceutical and biotechnological industries
- Foodstuff and beverage industry
- Microelectronics and semiconductor industries

GEMÜ - your valve and instrumentation partner.

State-of-the-art factory equipment and machinery plus a motivated team ensure the best service through our worldwide network of distributors and stockholding subsidiaries.

We are constantly making investments in order to optimise our existing products and to develop new products. Thus we can provide technical solutions for individual applications.





Contents

Multi-port valves for sterile applications	4 - 5
Advantages of M600 multi-port valves	6
i-bodies	7
Functions of M600 multi-port valves	8 - 9
Design of M600 multi-port valves	10 - 11
Design example of M600 multi-port valves	12
M600 03-01.EL / 03-01.ER	13
M600 03-02.B	14
M600 03-02.C	15
M600 03-02.SL / 03-02.SR	16
M600 03-03.N1 / 03-03.N3	17
M600 03-03.N2 / 03-03.N9	18
M600 04-04.N1 / 04-04.N2	19
M600 04-04.W	20
M600 04-05.R	21
M600 05-03.A7	22
M600 05-04.B	23
M600 05-04.C	24
M600 06-04.P1	25
M600 10-08.T	26
Materials and certificates	27
Butt weld connections	28
Clamp connections / Surface finish	29
Selection of operators - manual operators	30
Selection of operators - pneumatic operators	31
The original GEMÜ seal system / EHEDG certified seal system	32 - 33
Selection of diaphragms	34
How to specify M600 multi-port valves	36 - 37
Stainless steel valves for sterile applications	38

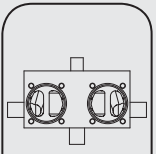

Multi-port valves for sterile applications

GEMÜ M600 multi-port valves are the most progressive solution for meeting the high demands of the pharmaceutical industry. Complex processes using welded fabrications are often still being implemented today, more than 15 years after the market launch of the first M-blocks. The valves, fittings and pipe components used for this require a lot of space, a greater installation and welding effort on site and lead to a correspondingly high validation expense. Not to mention a high hold-up volume and larger deadlegs in compliance with the conventional 6D or 3D rules.

To make processes safer, increase the availability of the plant and reduce the life cycle costs of a plant within the scope of a total cost of ownership concept, GEMÜ has implemented more than 400 different designs and thousands of customized variants of multi-port valves over the years. We support our customers with ideas and initial drafts at the planning phase. The drafts are then implemented constructively in our 3D CAD system, agreed in close co-operation with the customer and then machined in our highly efficient machine park. We machine several thousand blocks weighing between 0.1 kg and 500 kg per year on multi-axis machining centres. Every day, our Design Centre turns out new customized block designs.



Welded assembly



GEMÜ M600

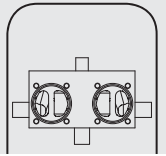

Advantages of GEMÜ M600 multi-port valves

- individual customized and very flexible design
- compact – low space requirements
- low hold-up volume, small wetted area
- greatly reduced deadlegs
- all blocks are designed for optimised draining
- machined from one block of material
- much greater product reliability
- no internal welds
- fewer fittings, welds and radiographic inspections
- standard welded ends for orbital welding
- reduced total cost of ownership
- operators and diaphragms from the proven GEMÜ modular system can be used
- reduced and simple validation
- made to customer specification

Conventional design

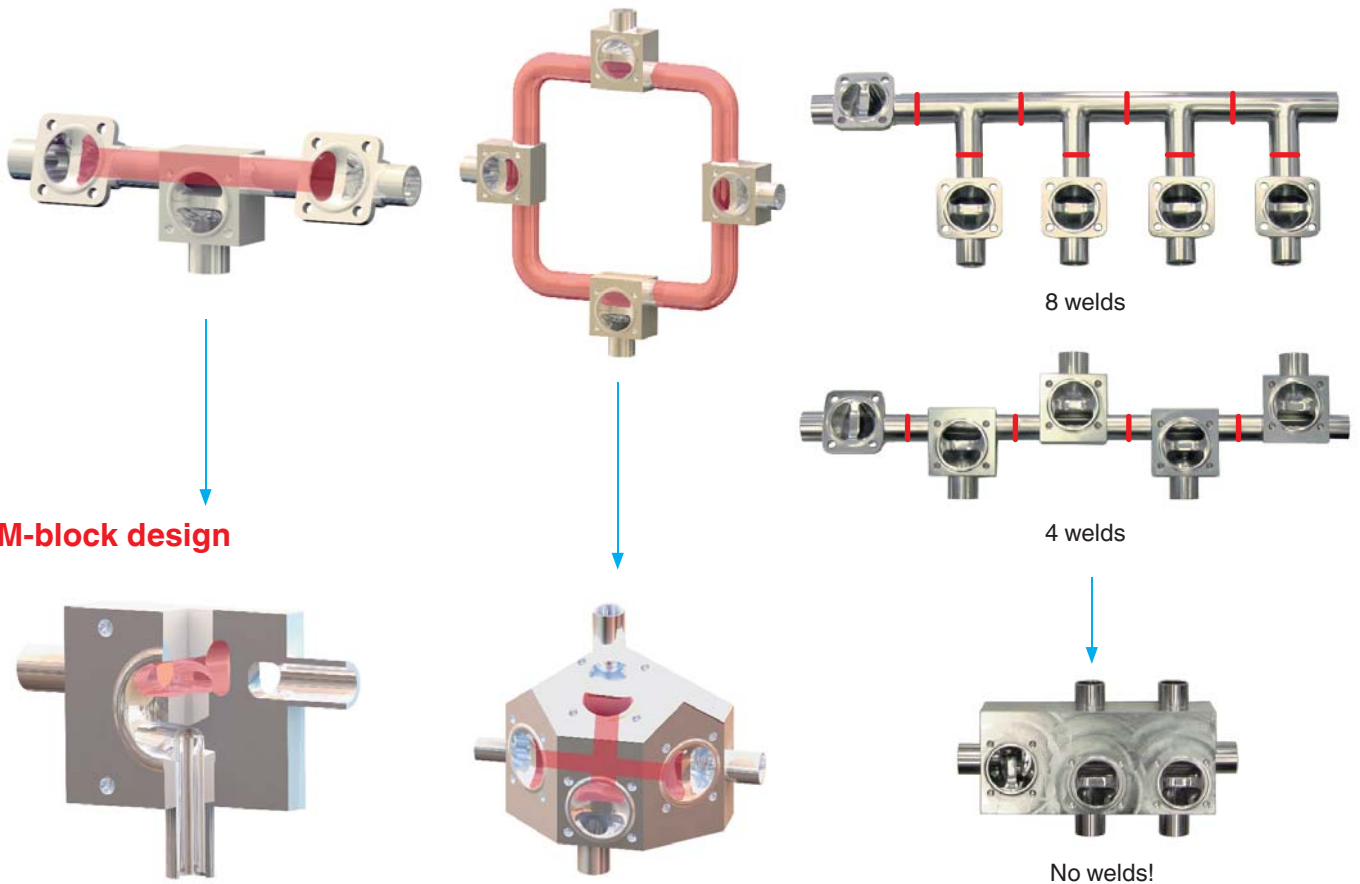

The red coloured line sections mark the hold-up volume

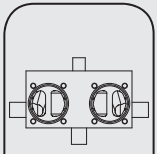

Advantages of M600 multi-port valves

SAP configuration

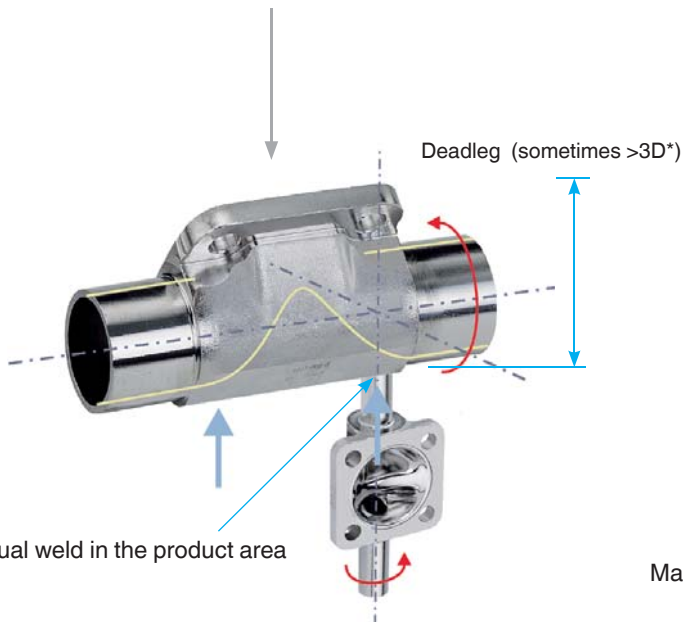
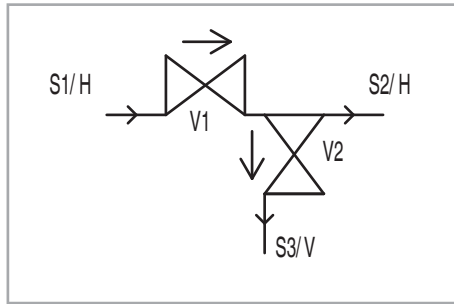

GMP configuration

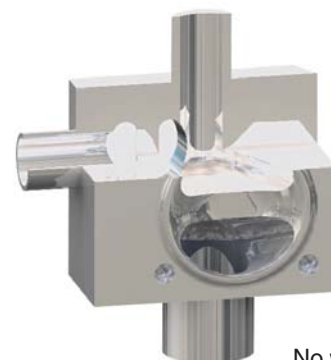
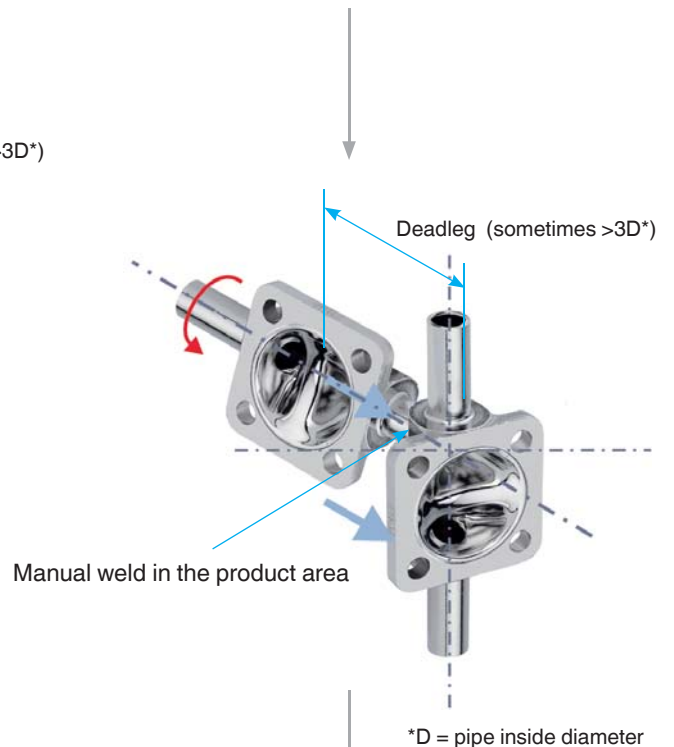
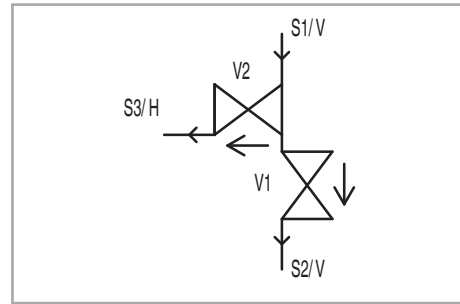

No weld in the product area.

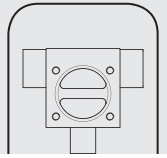

i-bodies

The evolution from welded SAP valve configurations according to the 6D- or 3D-rule to modern M-blocks shows the advantages of M-blocks very clearly. The GEMÜ i-body (integrated sampling valve) machined from either forged or solid material can be seen as an intermediate step to a full GEMÜ M-block design. It offers a low cost and good alternative to the M-block for a number of combinations.

The i-body already exhibits two essential features of an M-block. It has a greatly reduced dead volume and no welds in the product area. The drain or supply spigot is only welded on behind the valve seat. "i"-bodies are a special construction type of the classical 2/2-way bodies. "i" stands for integrated sampling, steam and condensate valve. The valve bodies have two valve seats and 3 pipe connections and are manufactured from a forging blank or a piece of block material. The major advantages of i-bodies compared to standard sampling or condensate valve bodies are as follows:

- Compact construction and reduced weight
- Minimal deadlegs
- No weld in the product area
- Horizontal spigot available
- No rear mounted operators
- Cost effective
- Draining in vertical mounting position possible if adhering to the 3D-rule
- Better drainability than with welded combinations
- Pneumatic and manual operators are available for both valve seats



Further information, dimensions and advice on request.

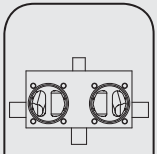

Functions of M600 multi-port valves

M-blocks can unite a wide variety of different functions in the smallest of spaces thanks to their individual design:

- mixing
- dividing
- feeding
- diverting
- discharging
- automatic switching

Quite substantial tasks are assigned to these individual functions in single applications. These are for example, sampling, sterile steam connection (SIP), connection for cleaning agent (CIP), guarantee of a minimum flow. In addition to this, there are numerous more complex functions in the scope of process automation.

In automatic measuring point switching in a plant, four measuring points are connected to one measuring instrument, for example, via one M-block. The measurements are made in a fixed rhythm. The media currents are controlled fully automatically by the PLC, the valve operators of which are connected to a central PLC.

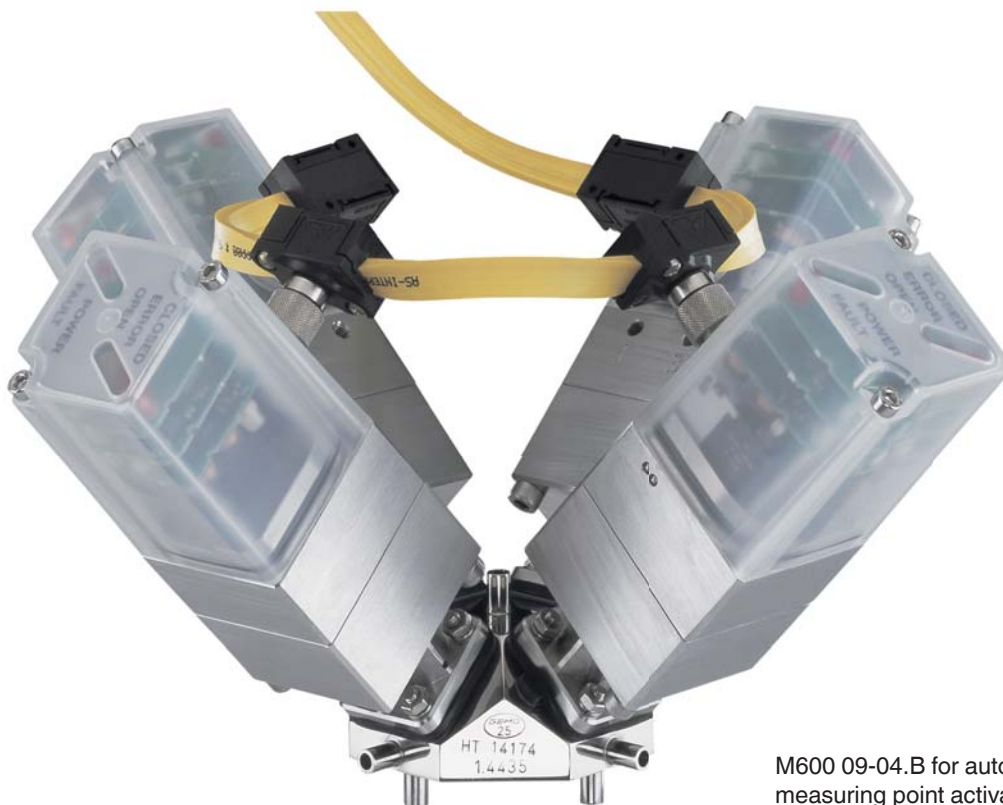

M600 09-04.B for automatic measuring point activation. Valve operator GEMÜ 651.

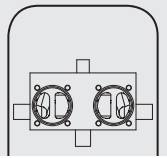

Another example is the automatic switching between two filters. If the set differential pressure in filter 1 is reached, the M-block automatically switches over to filter 2. This also ensures that the rest of the medium is fed through filter 2 again before backwashing filter 1. This means no medium is lost. The filters in the plant used to be flanged manually with the associated high risk of contamination and loss of valuable medium. This automatic switching could also be implemented previously by using welded configurations, but enhanced draining and the low space requirement are factors which promote the use of M-blocks for this application.

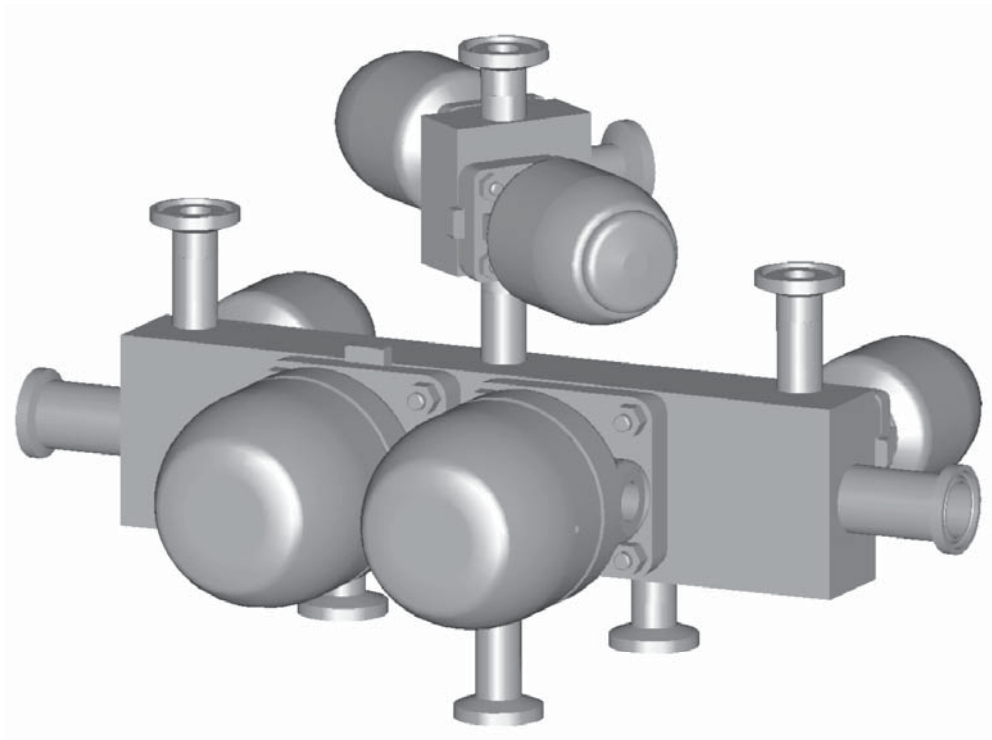
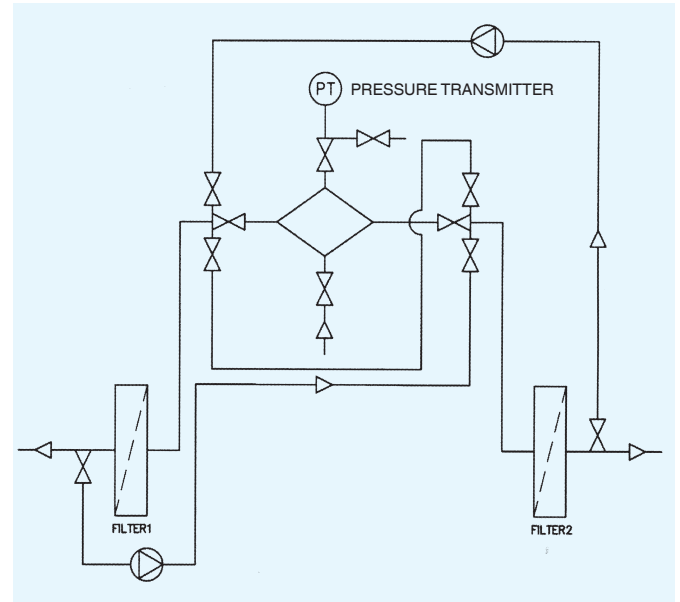

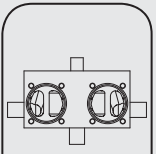

Design of M600 multi-port valves

A number of points need to be considered in the design and manufacture of M-blocks. First of all, there is the application and process safety for the plant in which the block is to be installed. The function of the block, number, dimensions and function of the pipe connections, number and size of the valve seats, mounting position of the block, space required, type and function of the actuators and the material type must be specified. Our engineers turn these specifications into your special solution.

A simple example is the modification of a normal T-valve into an M-block.



T-valve body

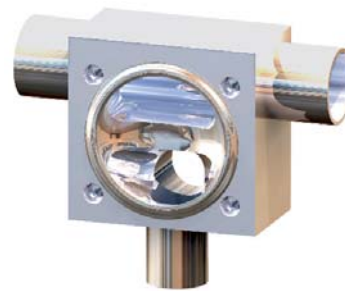

T-valve body with SAP connection



T-valve body with ring outlet



T-valve array

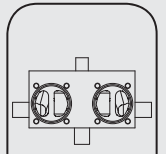

If, for example, a T-valve is combined with a steam connection, the block could look like this.

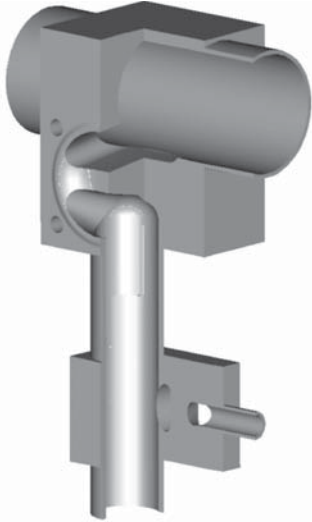

T-valve body with vaporisation valve

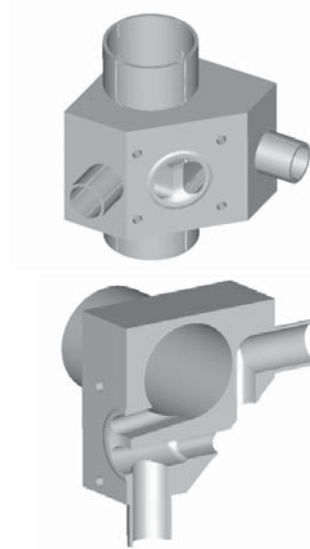

T-valve body with integrated insert

A more complex version is represented by the following WFI loop valve. There the functions removal, condensate outlet, pure steam supply and sampling are integrated in a compact block.

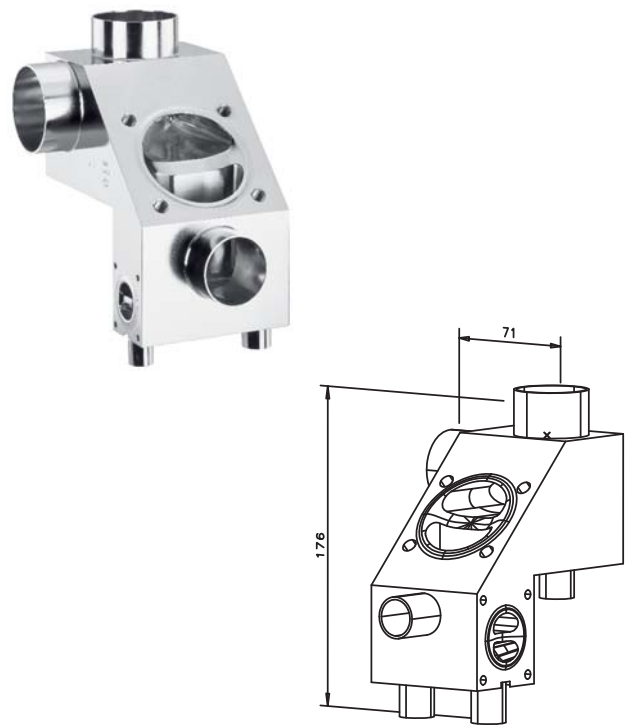
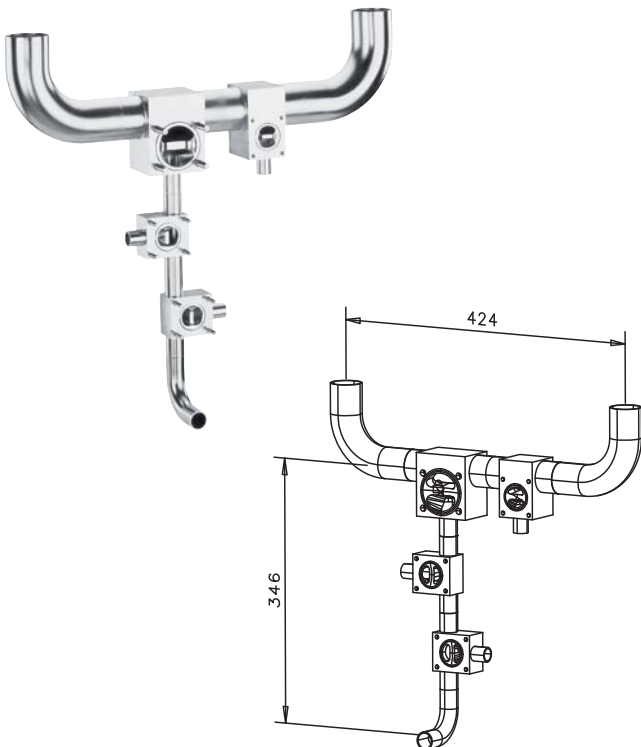

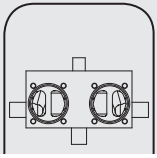

Design example of M600 multi-port valves

In order to be able to identify the M-blocks clearly later, a code has been generated at GEMÜ which should make communication easier

M600 06-04.P1

M600 always stands for multi-port valve

06 indicates the number of pipe ends

04 indicates the number of valve seats

The numbers at the end of the code indicate the design and variant details.

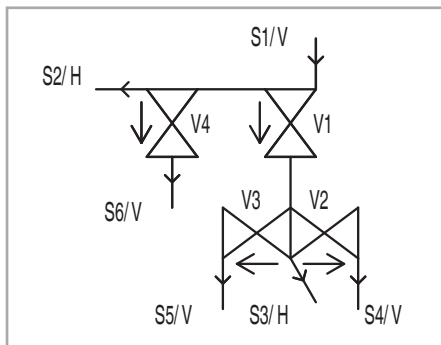

M600 06-04.P1

An initial analysis leads to a graphic design of the multi-port valve to be designed.
All customer specifications are treated strictly confidential.

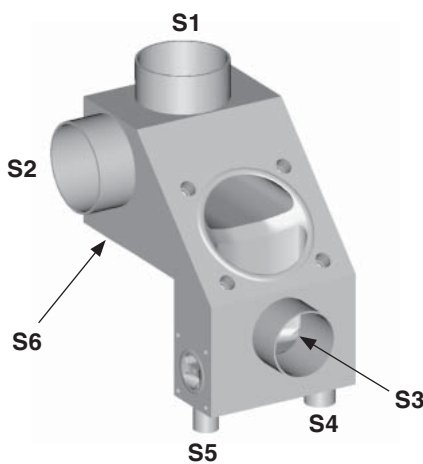

M600 06-04.P1

The schematic design then results in CAD based three-dimensional construction drawings.

M600 06-04.P1

We will produce the block individually for you after you have released it.

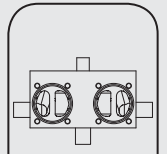

M600 03-01.EL / 03-01.ER

Sterile valve block made of stainless steel block material, application, for example, as a branch, sampling valve or insulation between two media rings. This depends, among other things, on whether the variant ER or EL is selected.

GEMÜ M600 03-01.EL

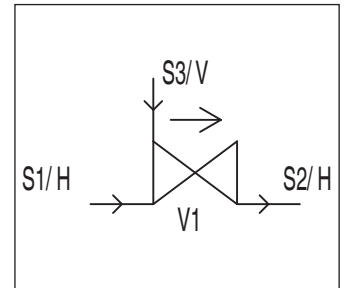
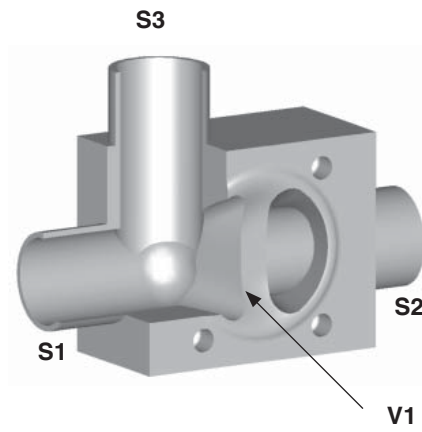
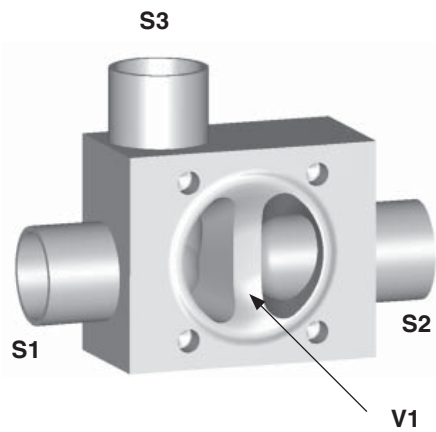

GEMÜ M600 03-01.ER

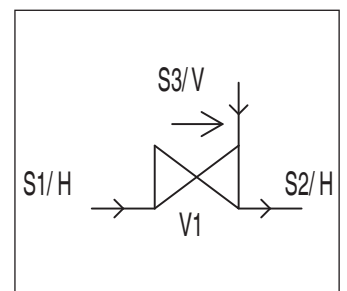
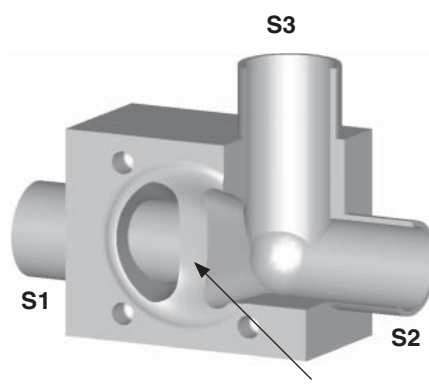
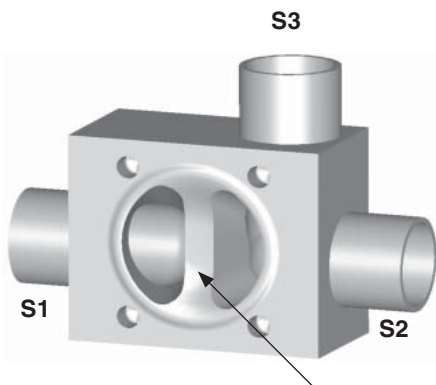

H = horizontal, V = vertical

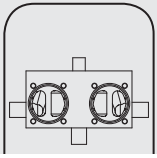

M600 03-02.B

Sterile valve block made of stainless steel block material, application, for example, as a collector or distributor.

Mounting position:

Spigot S1 aligned vertically up or down

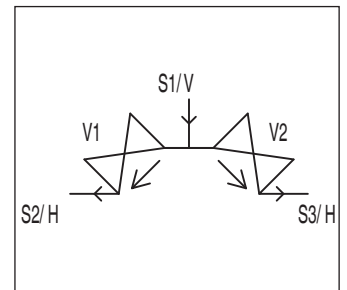
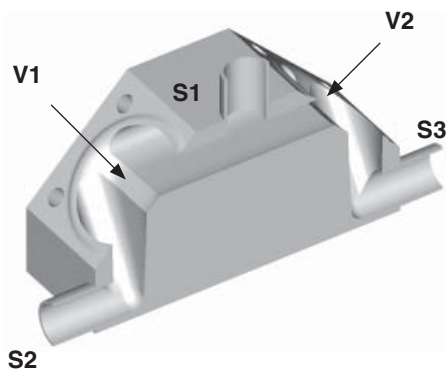
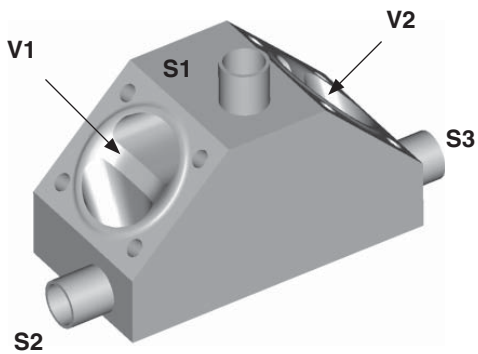

Alternative mounting position:

All spigots aligned horizontally

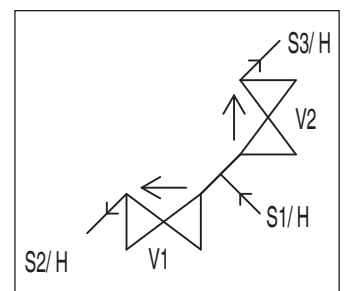
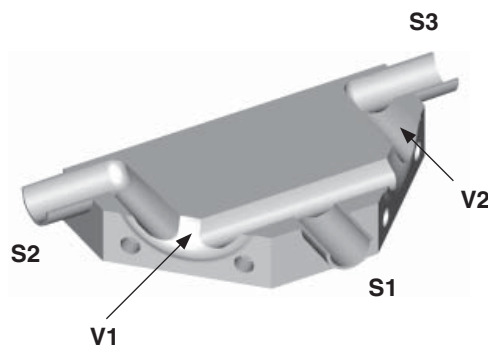
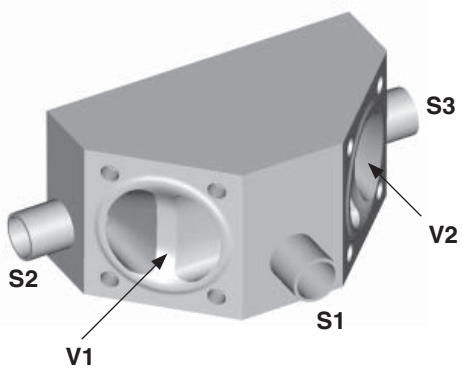

H = horizontal, V = vertical

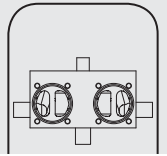

M600 03-02.C

Sterile valve block made of stainless steel block material, application, for example, as a collector, distributor or block-and-bleed valve, due to the spigot arrangement S2 and S3 requires less space than the M600 03-02.B version.

Mounting position:

Spigot S1 aligned vertically up or down

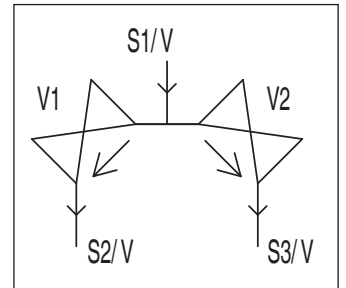
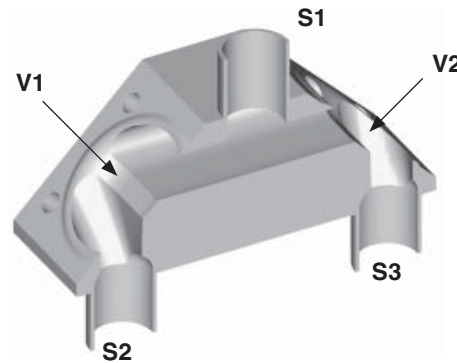
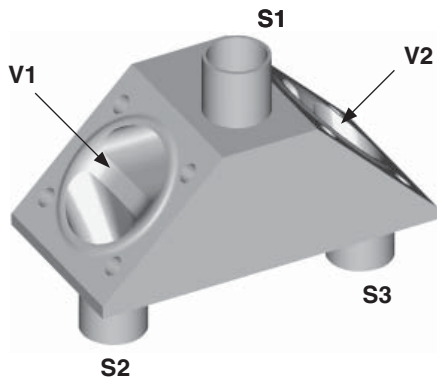

Alternative mounting position:

All spigots aligned horizontally

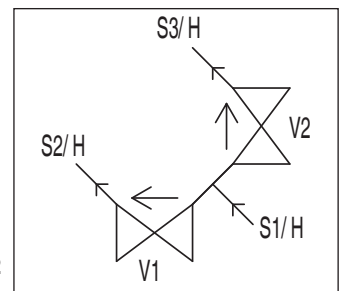
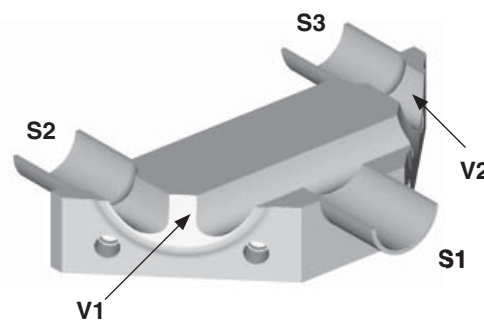
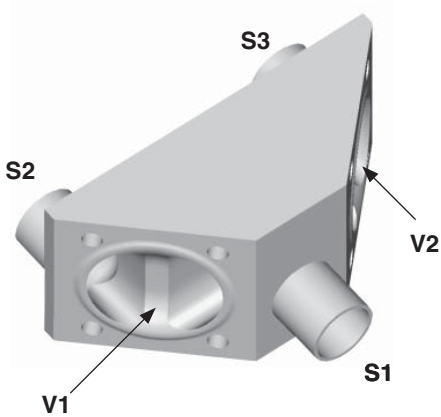

H = horizontal, V = vertical

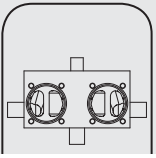

M600 03-02.SL / 03-02.SR

Sterile valve block made of stainless steel block material, application, for example, as a condensate drain or sampling valve.

GEMÜ M600 03-02.SL

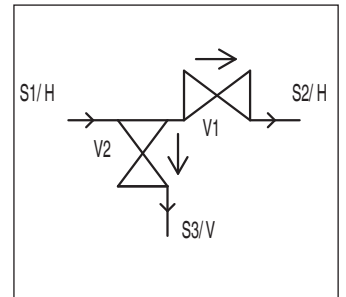
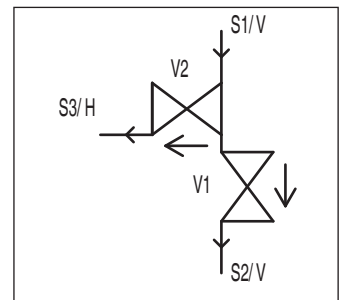
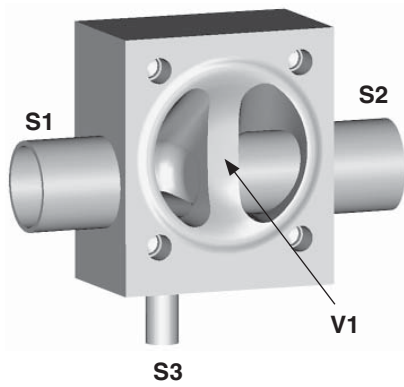
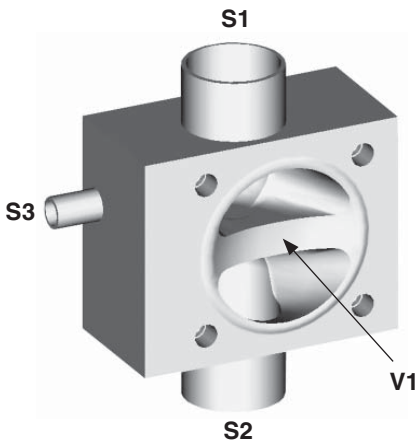

GEMÜ M600 03-02.SR

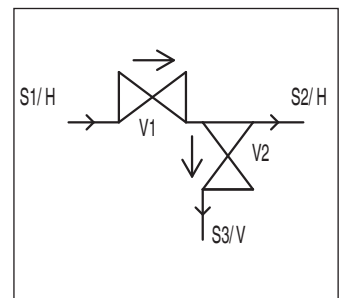
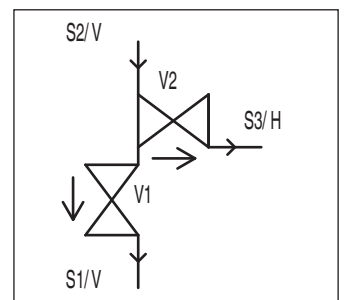
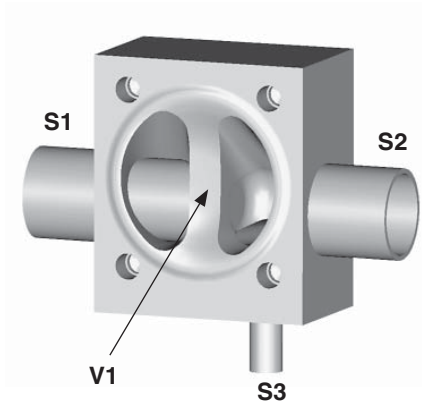
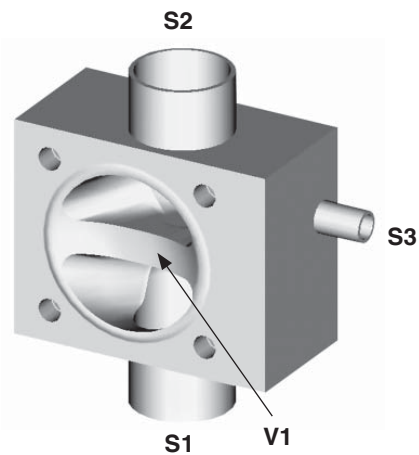

H = horizontal, V = vertical

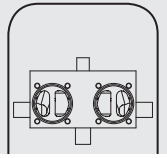

M600 03-03.N1 / 03-03.N3

Sterile valve block made of stainless steel block material, application, for example, as a block-and-bleed valve.

GEMÜ M600 03-03.N1

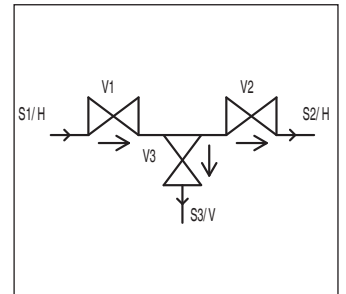
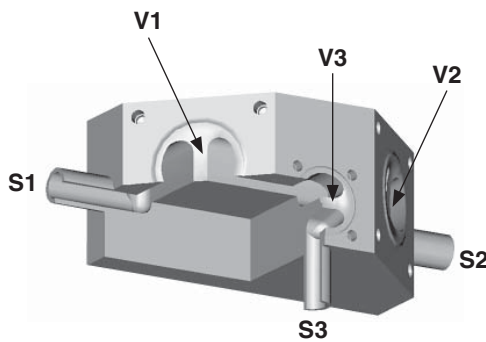
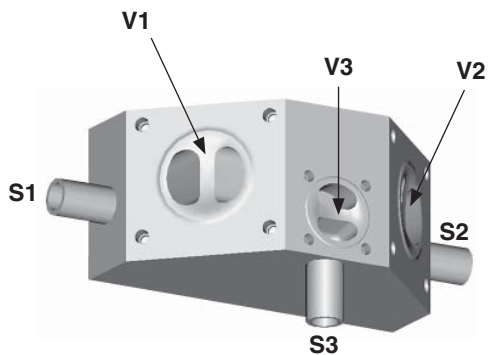

GEMÜ M600 03-03.N3

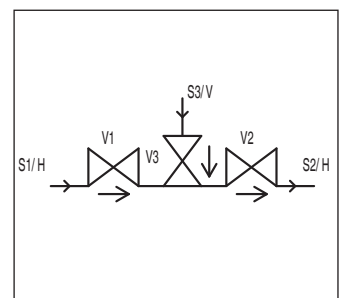
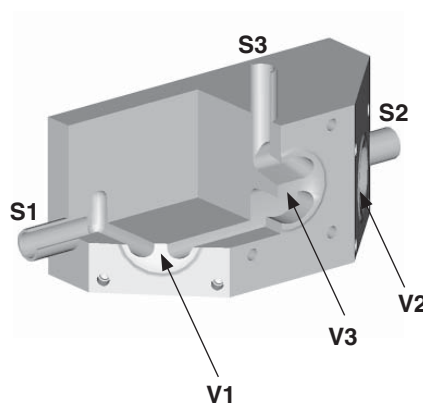
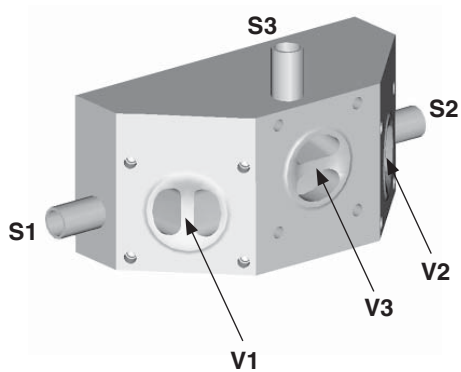

H = horizontal, V = vertical

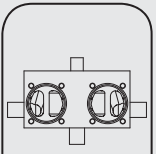

M600 03-03.N2 / 03-03.N9

Sterile valve block made of stainless steel block material, application, for example, as a block-and-bleed valve.

GEMÜ M600 03-03.N2

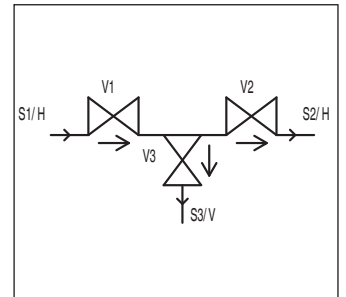
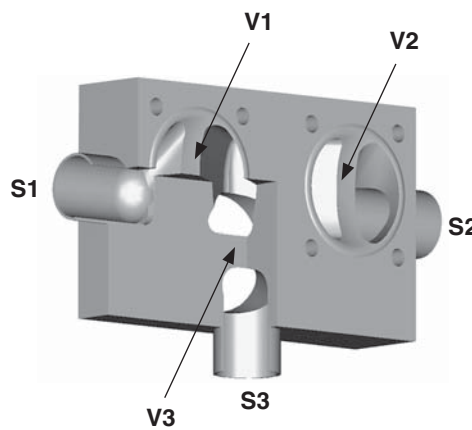
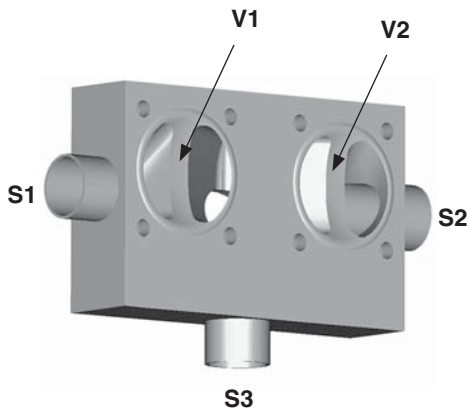

GEMÜ M600 03-03.N9

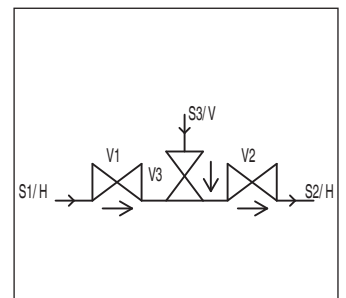
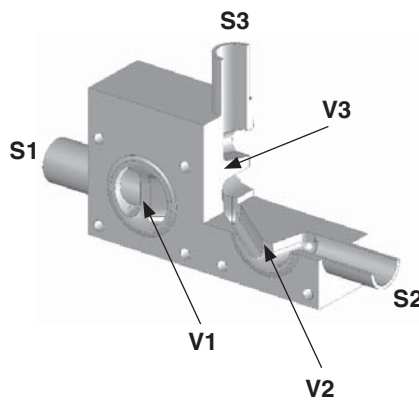
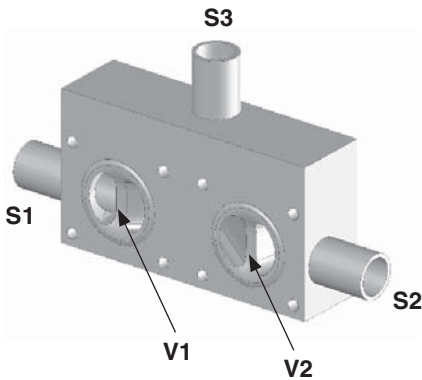

H = horizontal, V = vertical

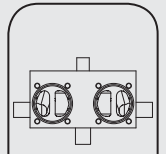

M600 04-04.N1 / 04-04.N2

Sterile valve block made of stainless steel block material, application, for example, as a double block-and-bleed valve.

GEMÜ M600 04-04.N1

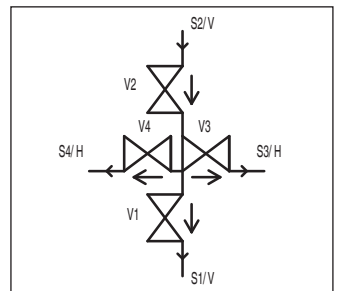
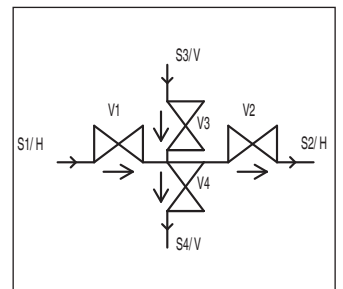
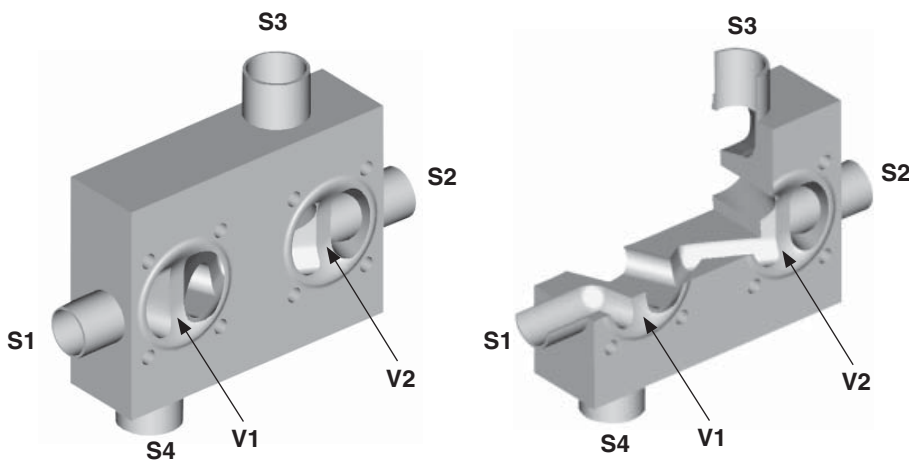

GEMÜ M600 04-04.N2

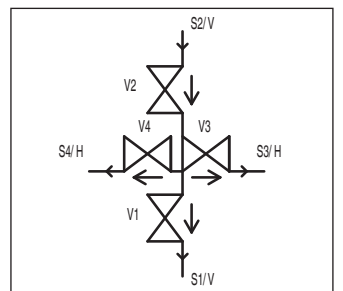
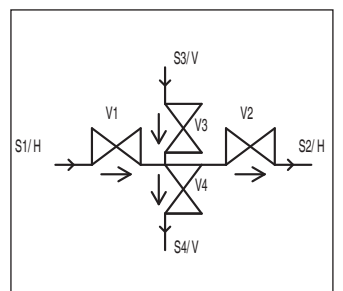
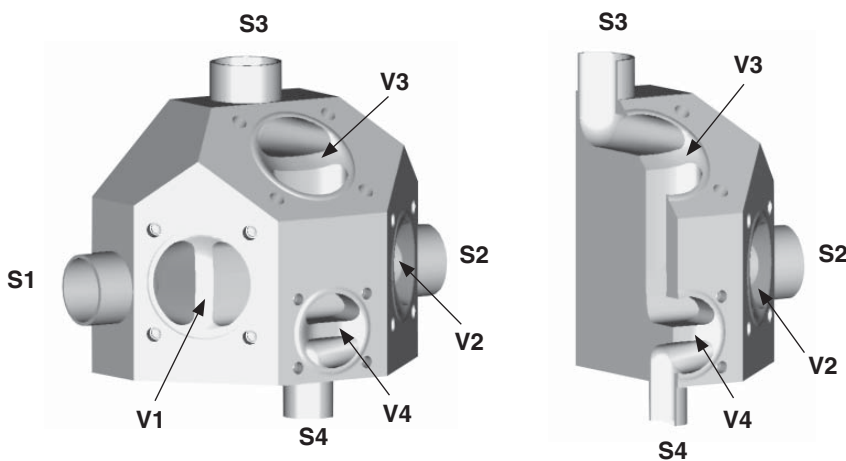

H = horizontal, V = vertical

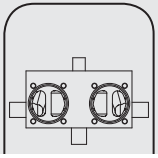

M600 04-04.W

Sterile valve block made of stainless steel block material, application, for example, as a distributor or collector.

Mounting position:

All spigots aligned horizontally

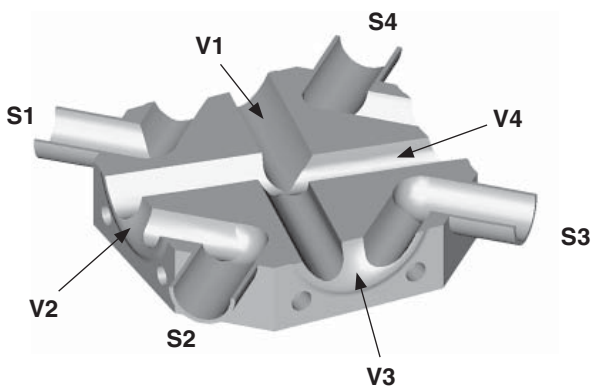
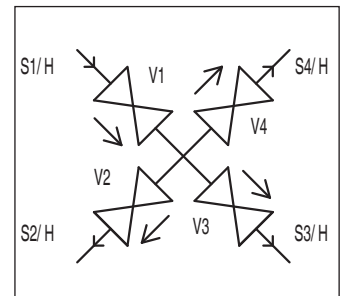
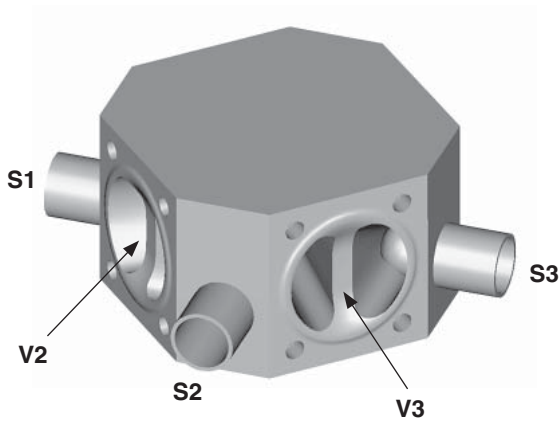

H = horizontal, V = vertical

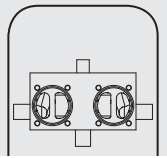

M600 04-05.R

Sterile valve block made of stainless steel block material, application, for example, as a chromatography block, conducting, diverting and switching.

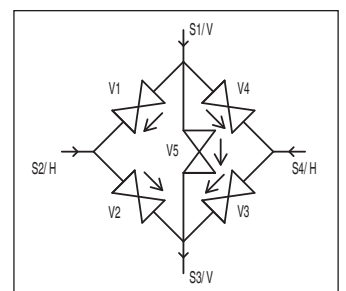
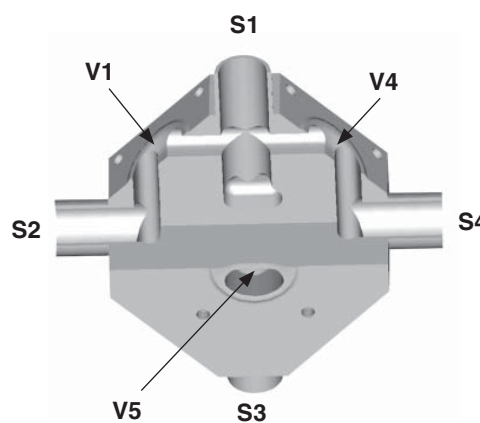
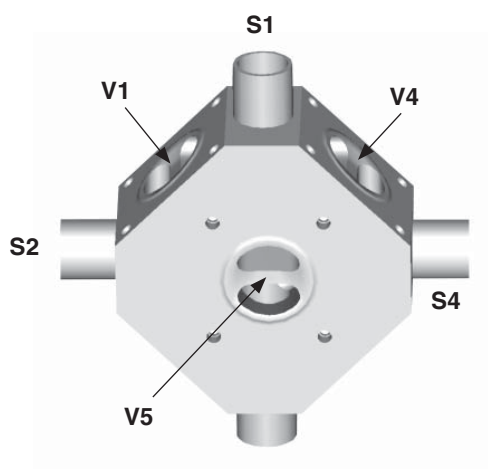
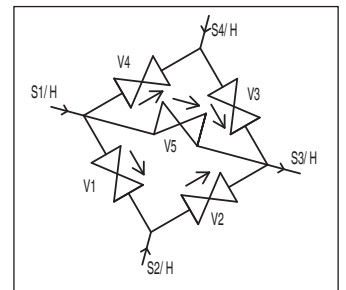
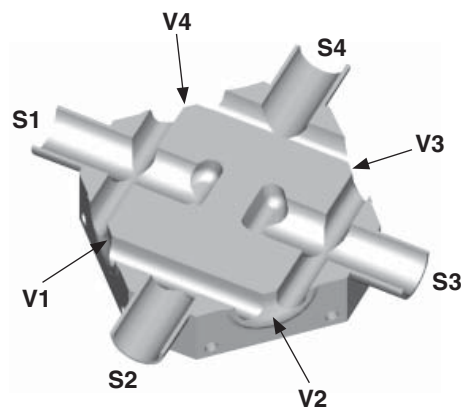
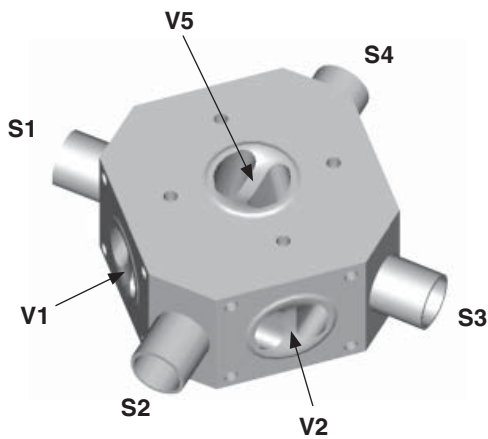

H = horizontal, V = vertical

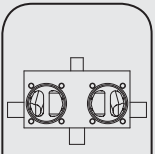

M600 05-03.A7

T-valve array with horizontal outlets.

Mounting position:

Main pipe at top

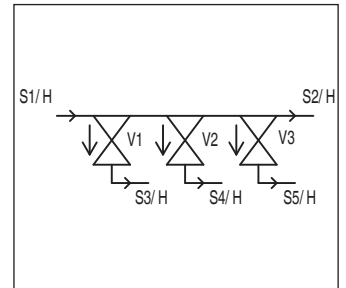
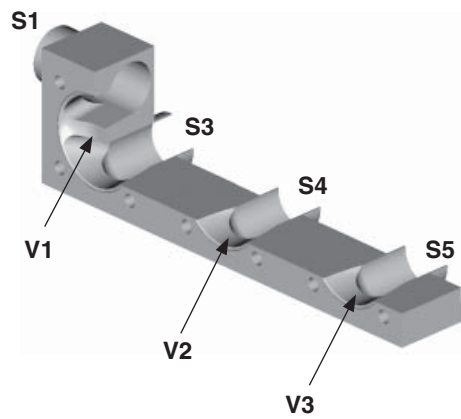
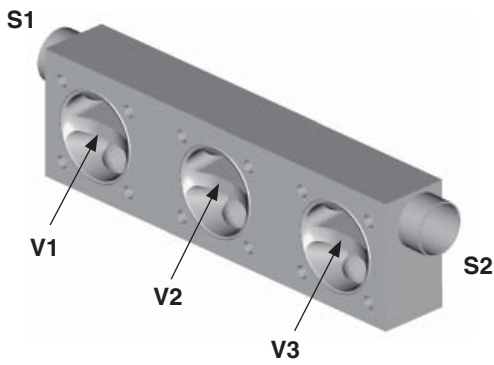

Alternative mounting position:

Main pipe at bottom

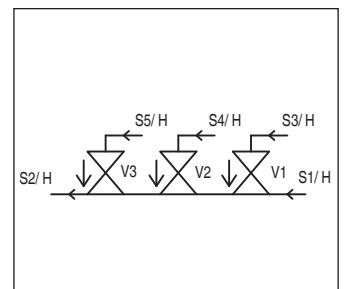
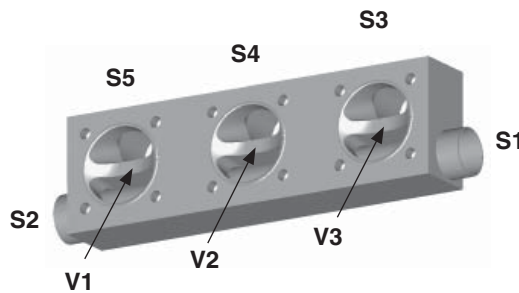
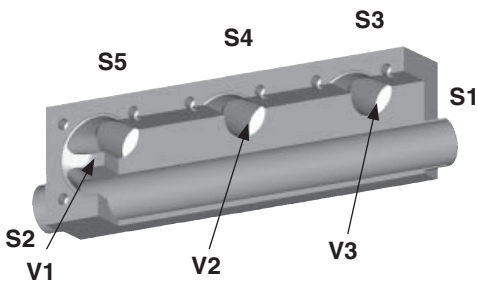

H = horizontal, V = vertical

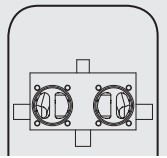

M600 05-04.B

Sterile valve block made of stainless steel block material, application, for example, as a collector or distributor.

Mounting position:

Spigot S1 aligned vertically up or down

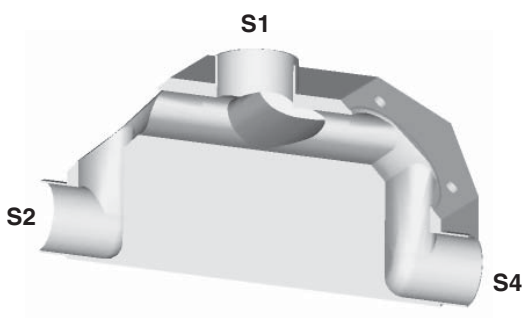
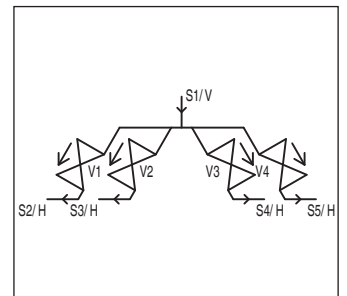
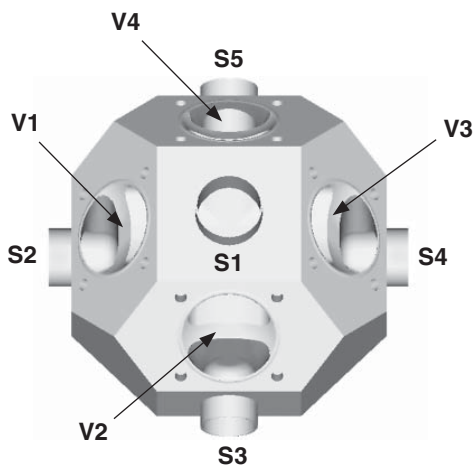

H = horizontal, V = vertical

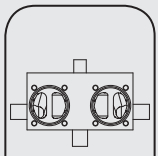

M600 05-04.C

Sterile valve block made of stainless steel block material,

application, for example, as a collector or distributor, due to the spigot arrangement S2-S5 requires less space than the M600 05-04.B version.

Mounting position:

Spigot S1 aligned vertically up or down

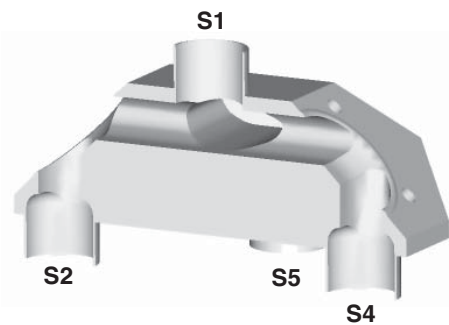
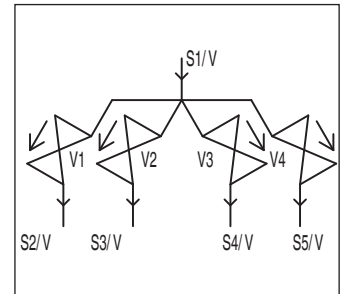
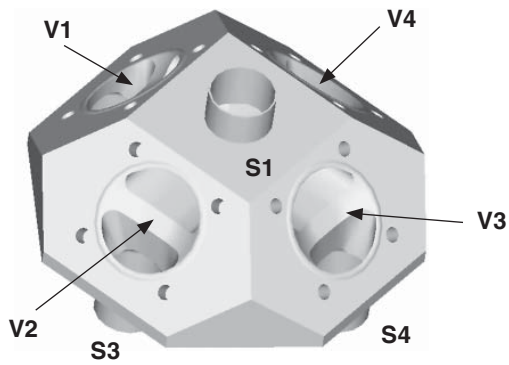

H = horizontal, V = vertical

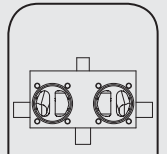

M600 06-04.P1

Sterile valve block made of stainless steel block material, multi-function block with several integrated applications: point of use WFI, sampling, condensate drain, filling into larger vessels, draining, sterile steam supply for SIP.

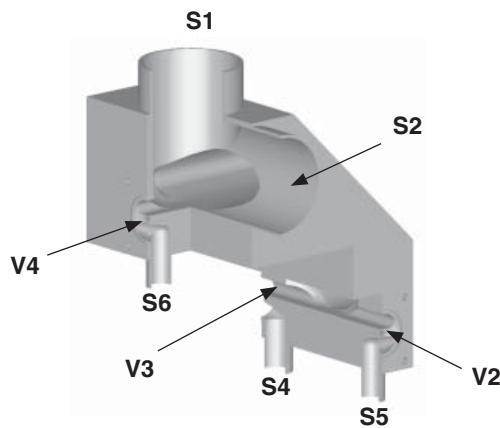
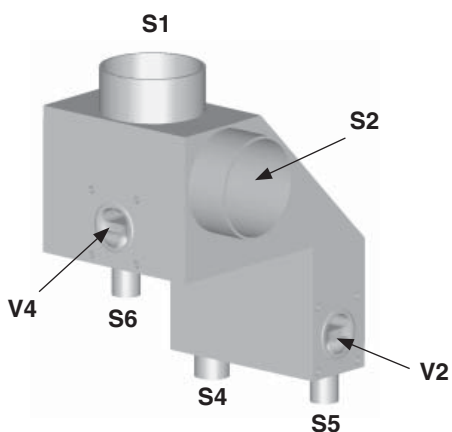
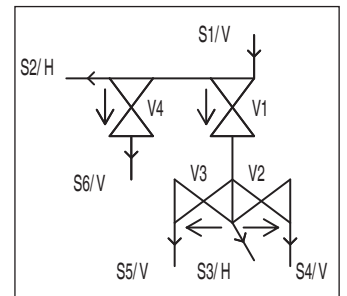
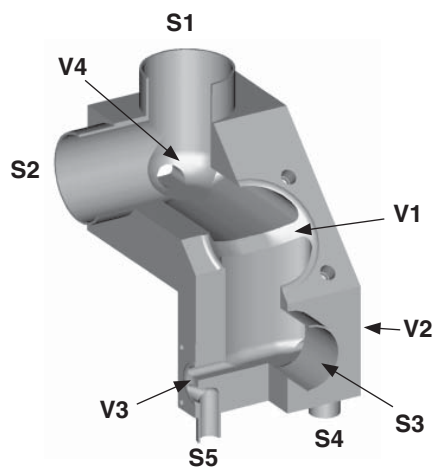
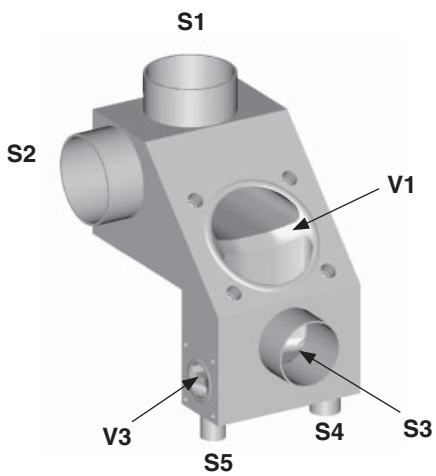

H = horizontal, V = vertical

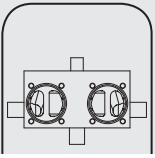

M600 10-08.T

Sterile valve block made of stainless steel block material, application, for example, as a T-valve array for branching and filling.

Mounting position:

Spigot S1 aligned vertically up

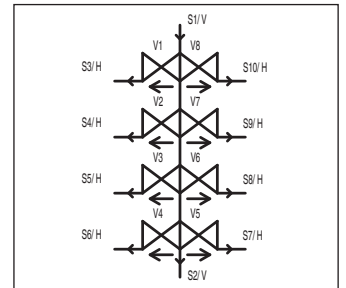
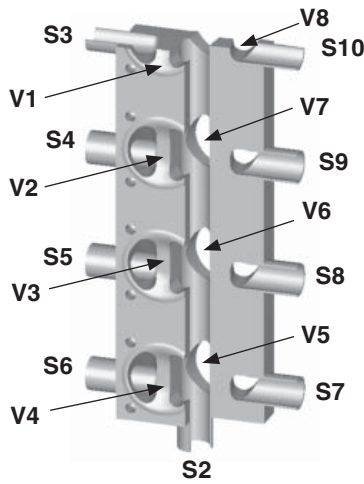
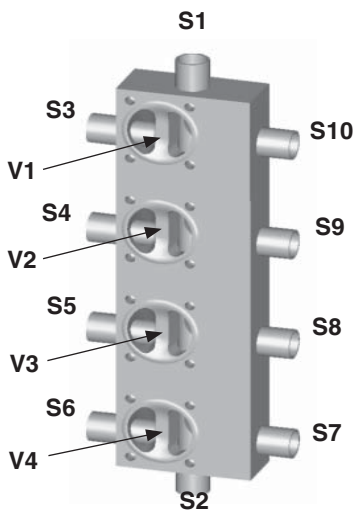

Alternative mounting position:

Spigots S3 to S10 aligned vertically

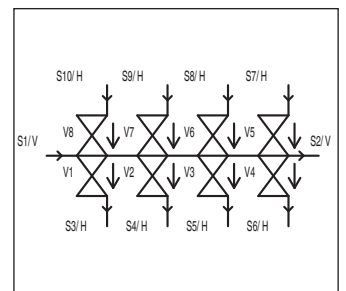
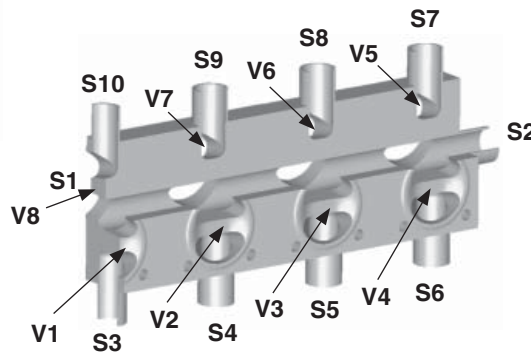
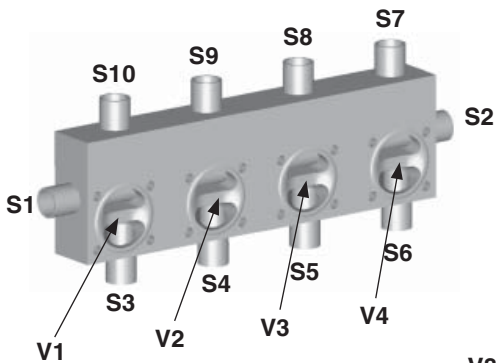

H = horizontal, V = vertical

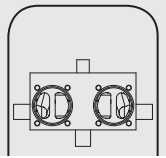

Materials and certificates

Multi-port valves are produced at GEMÜ from block material. The most frequently used material is 1.4435 (316L) and 1.4435 BN2 (316 L) with a ferrite content of < 0.5%. In addition, other common alloys such as 1.4539, Titanium, Alloy 59, Hastelloy C and special alloys are available by agreement.

The table below provides an overview of the possible certificates which are generally available. The type of certificate and its content must be specified exactly before ordering to be able to provide the required documents. Later requests of certificates may not be possible or possible only under certain conditions. Ask our specialists. They will be glad to help you.

Type	Designation of the test certificate in accordance with EN 10204	Content of the certificate	Confirmation of the certificate by
2.1	Certificate of compliance with the order	Confirmation of compliance with the order	the manufacturer
2.2	Test report	Confirmation of compliance with the order with specification of results of non-specific testing	the manufacturer
3.1	Inspection certificate 3.1	Confirmation of compliance with the order with specification of results of specific testing	manufacturers independent acceptance officer
3.2	Inspection certificate 3.2	Confirmation of compliance with the order with specification of results of specific testing	manufacturers independent acceptance officer

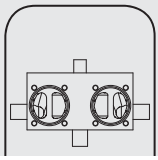

Butt weld connections

Dimensions in mm		EN ISO 1127	DIN	DIN 11850			DIN 11866	SMS 3008	BS O.D. 4825	ASTM 269 ASME BPE	JIS-G 3459	JIS-G 3447
DN	NPS	Code 60	Code 0	Series 1	Series 2	Series 3	Code 1A	Code 37	Code 55	Code 59	Code 36	Code 35
		ød x s	ød x s	ød x s	ød x s	ød x s	ød x s	ød x s	ød x s	ød x s	ød x s	ød x s
4	-	-	6 x 1.00	-	-	-	-	-	-	-	-	-
6	-	-	8 x 1.00	-	-	-	-	-	-	-	10.5 x 1.20	-
8	¼"	13.5 x 1.60	10 x 1.00	-	-	-	-	-	6.35 x 1.20	6.35 x 0.89	13.8 x 1.65	-
10	⅜"	17.2 x 1.60	-	12 x 1.00	13 x 1.50	14 x 2.00	13 x 1.50	-	9.53 x 1.20	9.53 x 0.89	17.3 x 1.65	-
15	½"	21.3 x 1.60	18 x 1.50	18 x 1.00	19 x 1.50	20 x 2.00	19 x 1.50	-	12.70 x 1.20	12.70 x 1.65	21.7 x 2.10	-
20	¾"	26.9 x 1.60	22 x 1.50	22 x 1.00	23 x 1.50	24 x 2.00	23 x 1.50	-	19.05 x 1.20	19.05 x 1.65	27.2 x 2.10	-
25	1"	33.7 x 2.00	28 x 1.50	28 x 1.00	29 x 1.50	30 x 2.00	29 x 1.50	25.0 x 1.20	-	25.40 x 1.65	34.0 x 2.80	25.4 x 1.20
32	1¼"	42.4 x 2.00	34 x 1.50	34 x 1.00	35 x 1.50	36 x 2.00	35 x 1.50	33.7 x 1.20	-	-	42.7 x 2.80	31.8 x 1.20
40	1½"	48.3 x 2.00	40 x 1.50	40 x 1.00	41 x 1.50	42 x 2.00	41 x 1.50	38.0 x 1.20	-	38.10 x 1.65	48.6 x 2.80	38.1 x 1.20
50	2"	60.3 x 2.00	52 x 1.50	52 x 1.00	53 x 1.50	54 x 2.00	53 x 1.50	51.0 x 1.20	-	50.80 x 1.65	60.5 x 2.80	50.8 x 1.50
65	2½"	76.1 x 2.00	-	-	70 x 2.00	-	70 x 2.00	63.5 x 1.60	-	63.50 x 1.65	76.3 x 3.00	63.5 x 2.00
80	3"	88.9 x 2.30	-	-	85 x 2.00	-	85 x 2.00	76.1 x 1.60	-	76.20 x 1.65	89.1 x 3.00	76.3 x 2.00
100	4"	114.3 x 2.30	-	-	104 x 2.00	-	104 x 2.00	101.6 x 2.00	-	101.60 x 2.11	114.3 x 3.00	101.6 x 2.00

The difference between tube specifications (Example DN 15)

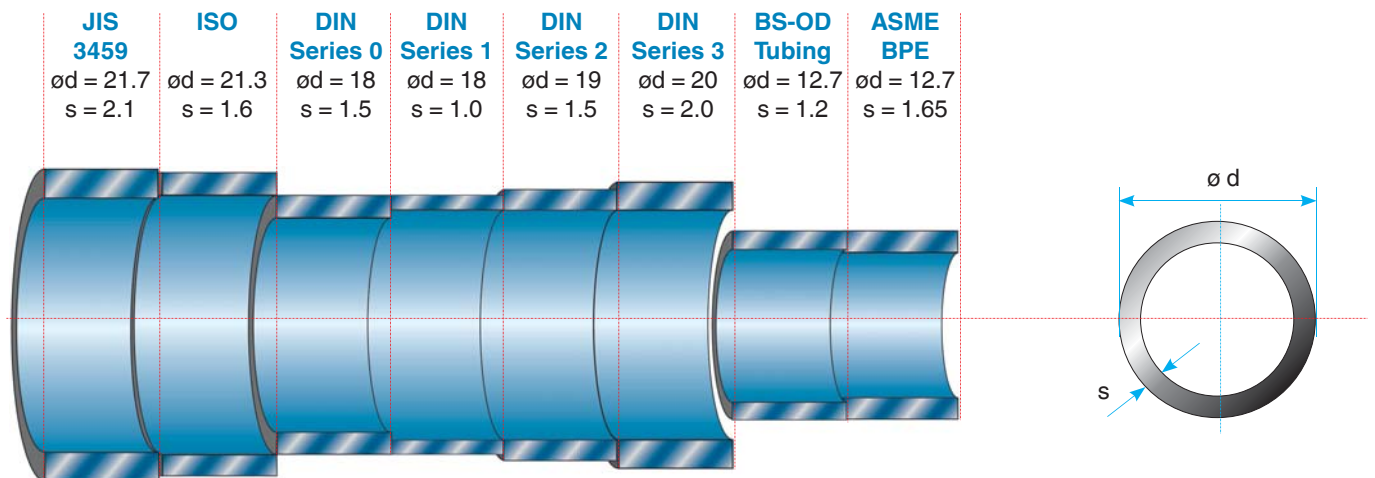

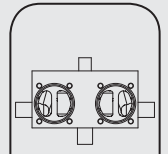

Clamp connections

All clamp connections are machined according to the spigot dimensions e.g. to DIN 11850, SMS 3008 or ASME BPE. We ask our customers to state which version or standard the connections shall comply with.

All welds are carried out by specially qualified and certified welders utilising state-of-the art welding technology.

In principle, special connections requested by customers can be provided on GEMÜ butt weld spigot bodies and it is also possible to have different connections on one body.

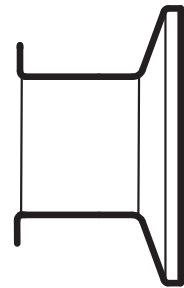

Clamp connections for M600 multi-port valves	Code
Clamps following ASME BPE for pipe EN ISO 1127, length EN 558-1 series 7	82
Clamps ASME BPE for pipe ASME BPE, length EN 558-1, series 7	88
Clamps DIN 32676 for pipe DIN 11850	86
Clamps SMS 3017 for pipe SMS 3008	87

Surface finish

Modern, ergonomically shaped workstations and trained polishers staff give us the ability to provide high quality surface finishes.

Depending on the required application, surface finishes from Ra 0.8 µm to 0.25 µm can be achieved by polishing, electro

polishing or a special process, we call "elysieren". Mechanical hand polishing is carried out at our works to ensure our high quality standard.

Valve body surface finish. internal contour	Code
Ra ≤ 0.8 µm mechanically polished internal, blasted external	1502
Ra ≤ 0.8 µm electropolished internal/external	1503
Ra ≤ 0.6 µm mechanically polished internal, blasted external	1507
Ra ≤ 0.6 µm electropolished internal/external	1508
Ra ≤ 0.4 µm mechanically polished internal, blasted external	1536
Ra ≤ 0.4 µm electropolished internal/external	1537
Ra ≤ 0.25 µm mechanically polished internal, blasted external	1527
Ra ≤ 0.25 µm electropolished internal/external	1516

Ra acc. to DIN 4768; at defined reference points

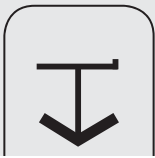

Selection of operators - manual operators

GEMÜ 601 / 602

with seal adjuster (GEMÜ 601),
with stainless steel hand wheel (GEMÜ 602),
autoclave capability



Diaphragm size 8

GEMÜ 612

with seal adjuster,
autoclave capability



Diaphragm size 10

GEMÜ 673

with seal adjuster,
autoclave capability



Diaphragm size 25-50

GEMÜ 653 BioStar®

with seal adjuster and stroke limiter,
autoclave capability



Design T
suitable for all body variants

Diaphragm size 10-100

GEMÜ 654 BioStar®

with seal adjuster and stroke limiter,
autoclave capability



Design T
suitable for all body variants

Diaphragm size 8-100



Selection of operators - pneumatic operators

GEMÜ 605

with optical position indicator



Diaphragm size 8

GEMÜ 625

with optical position indicator



Diaphragm size 10

GEMÜ 687



Diaphragm size 25-100

GEMÜ 650 BioStar®

with optical position indicator



Design T
suitable for all body variants

Diaphragm size 8-50

MG*	Diaphragm hole pattern	Possible operators		
		Manual	Pneumatic	Motorized
8	22 x 22	9601, 9602	9605, 9650	9618
10	39 x 44	9612, 9653, 9654	9625, 9650	9618
25	54 x 46	9653, 9654, 9673	9650, 9687, 9688	9698
40	70 x 65	9653, 9654, 9673	9650, 9687, 9688	9698
50	82 x 78	9653, 9654, 9673	9650, 9687, 9688	9698
80	127 x 114	9653	9687	
100	Ø 194	9653	9687	

* MG = Diaphragm size

Other versions, accessories as well as motorized operators available.
See brochure "Valves for Sterile Applications".

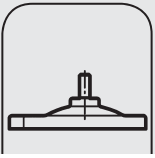

The original GEMÜ seal system

As a recognised diaphragm valve specialist, GEMÜ are familiar with almost all industrial sectors and applications. We are the leading supplier of stainless steel valves for sterile applications in the pharmaceutical industry, biotechnology industry, as well as the foodstuff and beverage industries. As well as this, our valves also stand for reliability and a high standard of quality in the chemical and processing industries. The diaphragm, a central sealing element in the piping system is of major importance. Only the diaphragm and the valve body are in contact with the medium. At the same time, they also guarantee external hermetic sealing of the pipeline.

The system is more than the sum of the individual parts

The outstanding characteristics of the diaphragm valve are the result of the perfect interaction of tuned components. These are the valve body, the shut-off diaphragm, the diaphragm fixing, the compressor, as well as the actuator. Our many years of experience and intensive dialogue with plant operators has enabled us to continue optimising the diaphragm valve design and its individual components.

Diaphragm and valve body are inseparable

GEMÜ valve bodies have a raised circular sealing bead on the inside diameter, in contrast to the valve bodies of other manufacturers. This results in a defined external sealing point. This measure reduces the ring-shaped gap between diaphragm and valve body in the external sealing area. This special feature makes GEMÜ diaphragm valves suitable for sterile applications. We also consider this crucial design and functional characteristic, which was developed by GEMÜ, during the development of our diaphragms. Only this ensures that our customers can rely on the valve as a complete unit.

GEMÜ diaphragms have been developed, tested, and approved for applications with GEMÜ valve bodies. We do not recommend or guarantee the use of diaphragms of other manufacturers with GEMÜ valve bodies due to the unique original GEMÜ seal system.

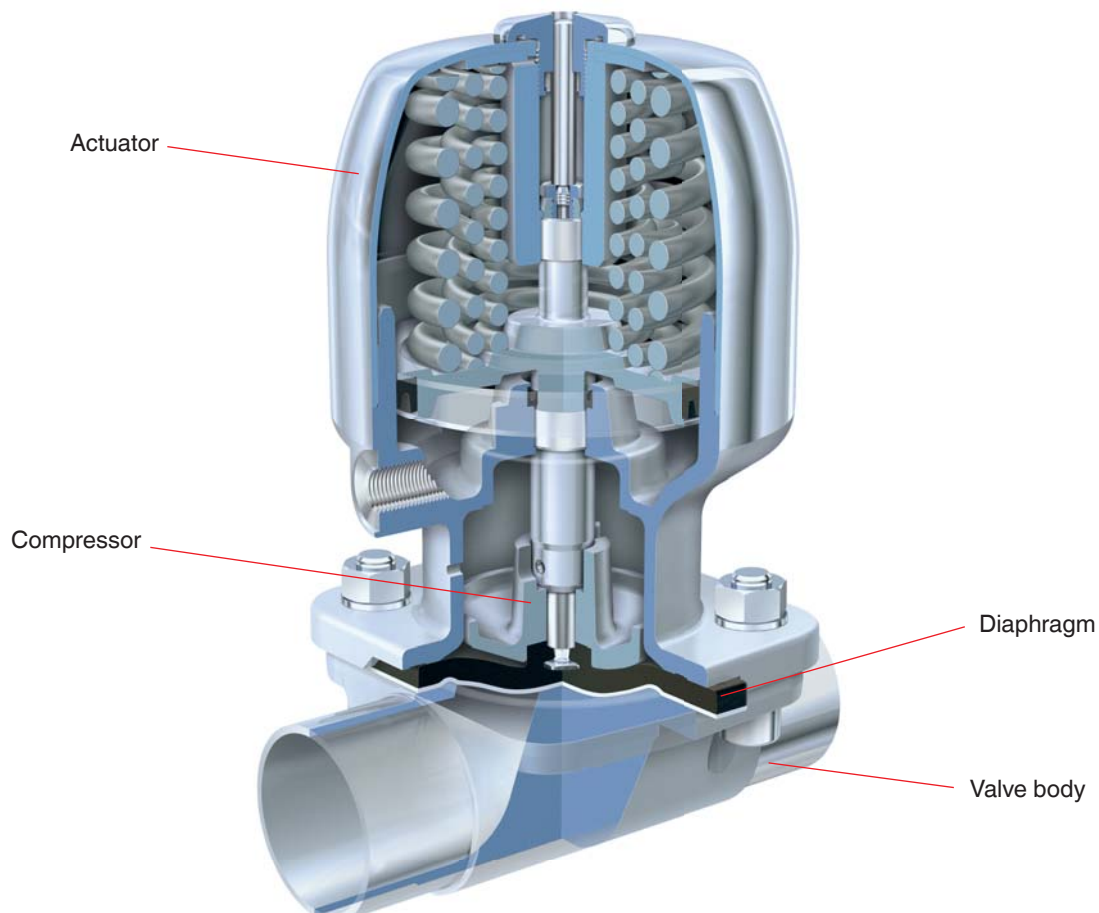

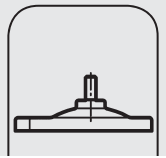

EHEDG certified seal system

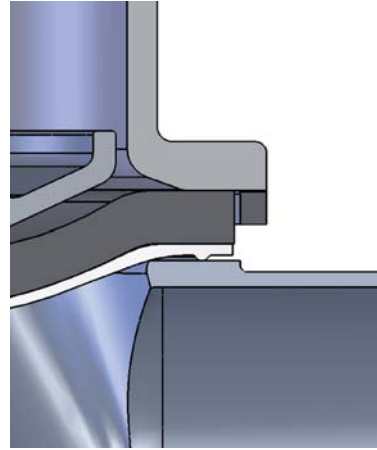
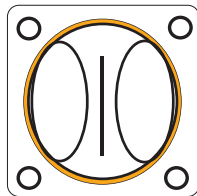
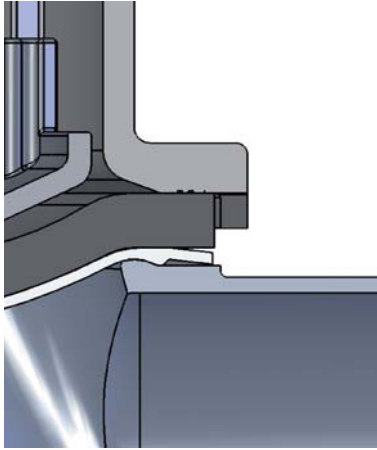

As a leading manufacturer worldwide we had the GEMÜ diaphragm seal system certified in 2002 and were granted the EHEDG certificate.



GEMÜ seal system

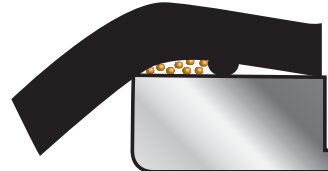

Conventional seal systems

GEMÜ flexible diaphragm fixing

The diaphragm is uniformly fixed in the compressor by means of a threaded pin. The only exception is the smallest diaphragm size (Diaphragm size 8), which is pushed in with a rubber pin. The uniform fixing method applies both to soft elastomer and PTFE diaphragms. The largest advantage of fixing by means of threaded pin, e.g. in comparison to a bayonet fitting, is that the force transfer is distributed onto the large area of the

flanks of the screw thread. This prevents damage to the mechanical connection between compressor and diaphragm especially under vacuum operating conditions. The uniform fixing of elastomer and PTFE diaphragms permits subsequent replacement of the diaphragms at any time without having to exchange the actuator because its mounting is different like other manufacturers.

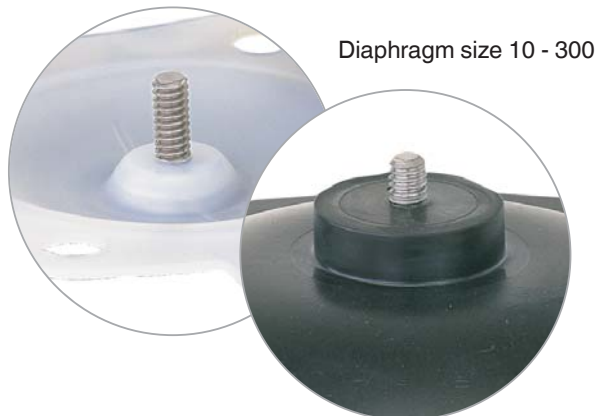

Diaphragm size 10 - 300

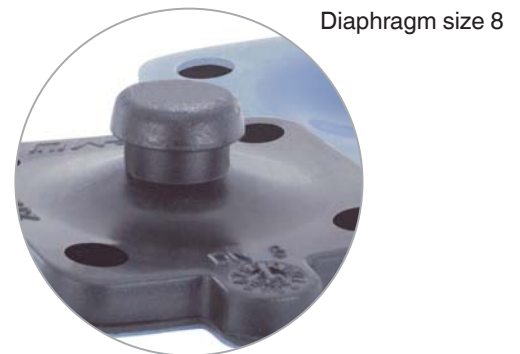

Diaphragm size 8

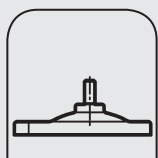

Selection of diaphragms

Each application must be analysed before the selection of the diaphragm material. Since the most varied operating conditions often prevail within a plant at different locations, it can be necessary to use different valves and materials. In particular, the chemical characteristics and the temperature of the working media often lead to different interactions. The suitability of the

materials used must therefore always be examined individually with regard to the current resistance list or checked by an authorised specialist. Only this procedure guarantees that the application will operate safely and economically for a longer period.

Diaphragm	Material/Design	MG*	Temperature range [°C]		Mechanical load capacity	Code	
			Liquid media Min.	Max.			
EPDM	Ethylene-propylene-diene rubber	8 - 100	-20	90	150°C max. 60 min.	***	13/3A
EPDM	Ethylene-propylene-diene rubber	8 - 100	-20	90	150°C max. 60 min.	***	16/6A
EPDM	Ethylene-propylene-diene rubber	8 - 100	-20	90	150°C max. 180 min.	*****	17
PTFE	Fully laminated PTFE diaphragm with EPDM back	8, 10, 100, 125, 150	-20	90	Constant temperature ¹ 150°C	*	52/5A
PTFE	Convex two-piece PTFE diaphragm with loose EPDM back	25, 40, 50, 80	-20	90	Constant temperature ¹ 150°C	**	5E

***** Highest mechanical load capacity

¹ The diaphragms are applicable as a moisture barrier. The valves concerned must be serviced regularly if steam is applied continuously.

*MG = Diaphragm size

Note:

Since plastics and elastomers are subject to natural aging, we recommend observing the GEMÜ storage conditions for shut-off diaphragms. You thereby guarantee maximum storage and service life of the diaphragms.

The temperature values are indicated irrespective of operating pressure and diaphragm size and apply to water and/or inert gases. The permissible operating pressure decreases with rising temperature and nominal size. Only specially designated diaphragms should be used for steam. The permissible operating pressure results from the steam pressure diagram.

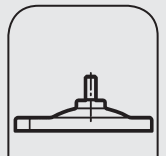

Exchangeability of diaphragms

Diaphragm size	Soft elastomer diaphragms (Code)	PTFE diaphragms (Code)
Diaphragm size 8	3A, 6A, 17	5A
Diaphragm size 10 + 100	13, 16, 17	52
Diaphragm size 25 - 80	13, 16, 17	52, 5E

Certificates und approvals*					Compatibility with media	Special features
FDA compliant	USP Class VI	EHEDG	TA-Air	O ₂ BAM		
X	X	X	X	X	Very good all-round elastomer, resistant to many acidic and alkaline media, demineralised and deionised hot water, inert and many other industrial gases.	Suitable for vacuum, low gas permeability, applicable for steam sterilisation.
X	X	X	X			Higher mechanical stability and service life in comparison to the diaphragm Code 13/3A during steam sterilisation, suitable for vacuum, low gas permeability.
X	X	X				Compound and construction of the diaphragm have been specially optimised for steam applications, clearly improved service life in comparison to the diaphragm Code 16/6A.
X	X	X	X		Resistant to nearly all chemicals, such as strong acids, alkalis and salts, also at higher temperatures, steam, WFI as well as pharmaceuticals. Good resistance to solvents, chlorine, and aromatic hydrocarbons.	Fully laminated diaphragm, can be used in steam. Low gas permeability.
X	X	X	X	X		Convex two-piece diaphragm with loose PTFE face for higher switching cycles, can be used for permanent steam application. Special compounding and production by GEMÜ. Special seal contour for external sealing on the bottom of the diaphragm. Low gas permeability.

* For details see pages 12-13.

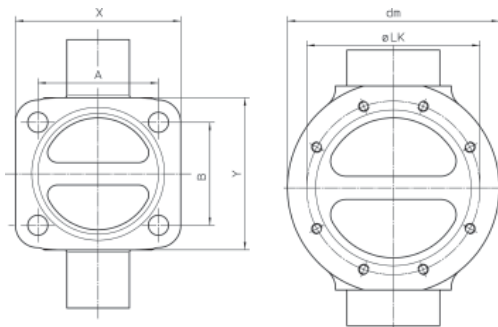

MG	Valve types	A	B	x	y	øLK	dm
8	601 / 602 / 605 / 650 / 654	22	22	32	32	-	-
10	611 / 612 / 615 / 625 / 650 / 653 / 654 / 660	39	44	50	55	-	-
25	671 / 673 / 687 / 695 / 650 / 653 / 654 / 660	54	46	74	68	-	-
40	671 / 673 / 687 / 695 / 650 / 653 / 654	70	65	102	92	-	-
50	671 / 673 / 687 / 695 / 650 / 653 / 654	82	78	125	110	-	-
80	671 / 687 / 653 / 654	127	114	192	162	-	-
100	671 / 687 / 653 / 654	-	-	-	-	194	234

* MG = Diaphragm size

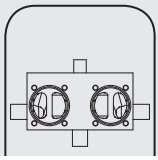

How to specify M600 multi-port valves

The consequential costs which may be incurred as a result of errors in the planning of production plant in the pharmaceutical industry more than justify increased planning efforts. Delays and extra costs in validation, late commissioning, contaminated batches, later modifications to the plant are just a few of the points in favour of precise planning.

Good planning of the valve designs begins in the project stage. The implementation of complex process sequences demands a wide variety of compact valve designs. GEMÜ places great emphasis on ensuring you get the optimum block for your specific application and not any standard solution from the catalogue. It is therefore important that you give us all the relevant information in the project phase. The GEMÜ specification sheet is a great help here. Please use only one form for each M-block and proceed as follows to fill in the specification.

M-blocks may be more expensive at first glance but are cheaper than conventional welded constructions when considering the whole application time in the plant. At the same time, they reduce process risks in the plant when installed correctly. The costs for removing a faulty welded configuration and the later replacement by an M-block by far exceed the higher purchasing costs for an M-block.

1. Enter the operating conditions and desired materials.
2. What functions should the M-block fulfil.
3. Draw a pictogram and make a sketch in the specification. You can of course use the examples shown in this brochure as a guide.
4. Label all connection spigots with S1, S2, ...
5. Assign the necessary features to every connection in the table and add explanatory remarks where necessary.
6. Specify the necessary operator type and control function for every connection.
7. For extra remarks and descriptions, simply use an additional sheet

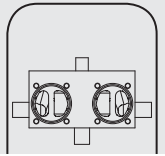

M600 Specification

Please complete this form and return it to your nearest GEMÜ office or to the address listed below!

Operating pressure: _____ bar

Medium temperature: _____ °C

Multi-port valve material:

- 1.4435
- 1.4435 BN 2 ($\Delta Fe < 0.5\%$)
- 1.4539
- Other _____

Diaphragm material:

- EPDM Code _____
- PTFE Code _____
- Other _____

Surface finish of M600 multi-port valve:

- 1502 (Ra) ≤ 0.8 μm
- 1503 (Ra) ≤ 0.8 μm electropolished
- 1507 (Ra) ≤ 0.6 μm
- 1508 (Ra) ≤ 0.6 μm electropolished
- 1536 (Ra) ≤ 0.4 μm
- 1537 (Ra) ≤ 0.4 μm electropolished
- 1527 (Ra) ≤ 0.25 μm
- 1516 (Ra) ≤ 0.25 μm electropolished

Quantity:

Example:

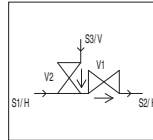

Please draw functional diagram.

Note: Please observe correspondence of table and functional diagram.

Spigot: S1, S2, ...

Preferred mounting position: Horizontal/Vertical

Flow direction (medium): →

Draining direction: →

Valve seat:

Spigot		Pipe connection			Operator		Other
Spigot no.	DN	s[mm]	ød(a)mm]	Code	Operator type	Control function	Comment / accessories
S1							
S2							
S3							
S4							
S5							
S6							
S7							
S8							
S9							
S10							
S11							
S12							

The technical details of each enquiry will be checked by GEMÜ.

Contact (GEMÜ): _____
Customer: _____
 Department: _____
 Address: _____
 Phone: _____ Fax: _____

Please do not write here!

Version: _____
 990
 LZ: _____
 Price*: _____

*€/body

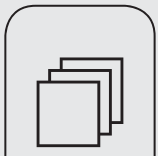

Stainless steel valves for sterile applications



Stainless steel diaphragm valves

Complete range of "Valves for Sterile Applications". Includes an overview of the GEMÜ aseptic valves, available body configurations, connections, nominal sizes and accessories.



T Valves for Sterile Applications

Partial overview of available GEMÜ T valves and their dimensions.



2/2-Way Valve Bodies for Sterile Applications

Partial overview of available GEMÜ 2/2-way valve bodies and their dimensions.

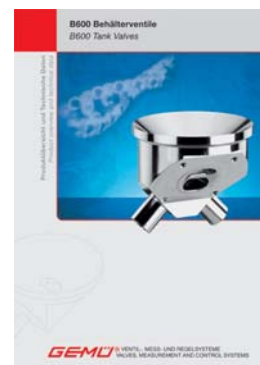

B600 Tank Valves

Partial overview of GEMÜ B600 tank valves, variations and specification form.

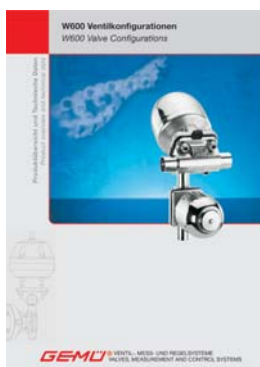

W600 Valve configurations

Partial overview of available GEMÜ W600 valve configurations, variations and specification form.



Diaphragms

Overview of available GEMÜ diaphragms, materials used and areas of use for GEMÜ diaphragm valves.

Globe and Control Valves

Complete globe valve range.
Includes an overview of the GEMÜ globe and control valves, available body configurations, connections, nominal sizes and accessories.



Dear Customer,

When installing GEMÜ products all current standards, provisions, directives and regulatory codes must be followed. The application of other technical regulations during installation may also depend on local or relevant industrial guidelines and is the responsibility of our customers.

GEMÜ cannot accept any liability for improper installations which do not comply with current legal and engineering practise.

We reserve the right to make technical alterations to products as a result of developments. The technical data specified in this documentation serves only as a guideline to our product range. The application and use of these products needs to be checked by the user in every case.



GEMÜ® VALVES, MEASUREMENT
AND CONTROL SYSTEMS

GEMÜ Gebr. Müller Apparatebau GmbH & Co. KG · Fritz-Müller-Str. 6-8 · D-74653 Ingelfingen-Criesbach · Tel. +49(0)7940/123-0 · Fax +49(0)7940/123-224
info@gemue.de · www.gemue.de